

Conventional and Addressable Accessories

Hazardous Location Signals

105 Series

Edwards 105 Series Xenon strobe beacons are heavy-duty visual signals suitable for use in indoor and outdoor applications where a corrosion resistant Type 4X enclosure is required. Base material is gray, manufactured from glass-reinforced thermoplastic polyester resin and features brass hardware. The double fresnel lens is made of shatter-resistant polycarbonate. The 105DHISTC-FJ high intensity strobe is designed for use in compatible fire alarm system and other applications requiring electrical supervision of signaling circuit field wiring.

Features and Specifications

- Xenon strobe light source
- Shatter-resistant double fresnel polycarbonate lens
- Gray base with brass hardware
- Flash rate 65 fpm
- Suitable for indoor, outdoor and marine applications
- For outdoor applications, lens should face up
- Option for panel, conduit or wall mounting
- NEMA Type 4X enclosure
- Class I, Div 2, Groups A, B, C and D; Class II, Div 2, Groups F and G; Class III



Ordering Information

Description	Cat. No.	Operating Voltage	Current	Lens Colors	Peak Candlepower	Lamp Ratings ¹	Replacement Lamp
Fire Alarm (UL 1971) 8 Joule Strobe	105DHISTC-FJ	20-30V DC	1.08 - 0.83 A	Clear	26 cd wall (dome out) 24 cd wall (dome down) 26 cd ceiling	3,000 hours	92-ST

¹Strobe tube life at operating power to 75% efficiency.

Accessories²

Description	Cat. No.
Wall Mount Bracket	105BM³
Outlet Box Attachment	105BX
Pipe Mount Attachment	105PM



Wall Mount Bracket



Outlet Box Attachment



Pipe Mount Attachment

²Mounting accessories must be ordered separately.

³Must be used with 105BX.

Hazardous Location Ratings

105DHISTC-FJ	Class	Division	Group	Operating Temperature
	II	2	F, G	TB3 (165°C, 329°F)



Conventional and Addressable Accessories

Hazardous Location Signals

105 Series

Weights and Dimensions

Cat. No.	Approx. Shipping Weight (lb.)
105DHISTC-FJ	1.63
105BM	1.00
105BX	1.00
105PM	1.00

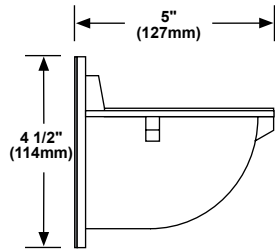
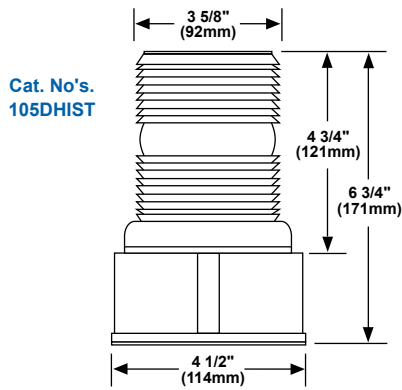

Cat. No. 105BM Mounting Bracket
(use with 105BX)

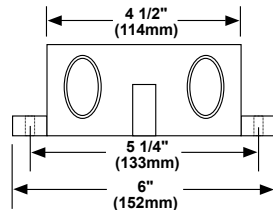

Cat. No. 105BX
Outlet Box Attachment

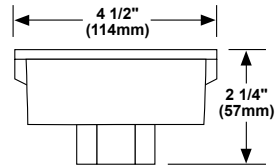

Cat. No. 105PM
Pipe Mount Attachment
(3/4" NPT Conduit Size)

Conventional and Addressable Accessories

Hazardous Location Signals

105 Series

Edwards 105 Series Xenon strobe beacons are heavy-duty visual signals suitable for use in indoor and outdoor applications where a corrosion resistant Type 4X enclosure is required. Base material is gray, manufactured from glass-reinforced thermoplastic polyester resin and features brass hardware. The double fresnel lens is made of shatter-resistant polycarbonate. The 105DHISTC-FJ high intensity strobe is designed for use in compatible fire alarm system and other applications requiring electrical supervision of signaling circuit field wiring.

Features and Specifications

- Xenon strobe light source
- Shatter-resistant double fresnel polycarbonate lens
- Gray base with brass hardware
- Flash rate 65 fpm
- Suitable for indoor, outdoor and marine applications
- For outdoor applications, lens should face up
- Option for panel, conduit or wall mounting
- NEMA Type 4X enclosure
- Class I, Div 2, Groups A, B, C and D; Class II, Div 2, Groups F and G; Class III



Ordering Information

Description	Cat. No.	Operating Voltage	Current	Lens Colors	Peak Candlepower	Lamp Ratings ¹	Replacement Lamp
Fire Alarm (UL 1971) 8 Joule Strobe	105DHISTC-FJ	20-30V DC	1.08 - 0.83 A	Clear	26 cd wall (dome out) 24 cd wall (dome down) 26 cd ceiling	3,000 hours	92-ST

¹Strobe tube life at operating power to 75% efficiency.

Accessories²

Description	Cat. No.
Wall Mount Bracket	105BM³
Outlet Box Attachment	105BX
Pipe Mount Attachment	105PM



Wall Mount Bracket



Outlet Box Attachment



Pipe Mount Attachment

²Mounting accessories must be ordered separately.

³Must be used with 105BX.

Hazardous Location Ratings

105DHISTC-FJ	Class	Division	Group	Operating Temperature
	II	2	F, G	TB3 (165°C, 329°F)



Conventional and Addressable Accessories

Hazardous Location Signals

105 Series

Weights and Dimensions

Cat. No.	Approx. Shipping Weight (lb.)
105DHISTC-FJ	1.63
105BM	1.00
105BX	1.00
105PM	1.00

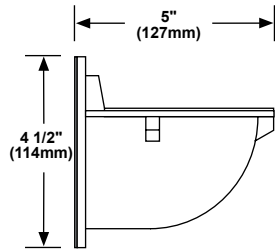
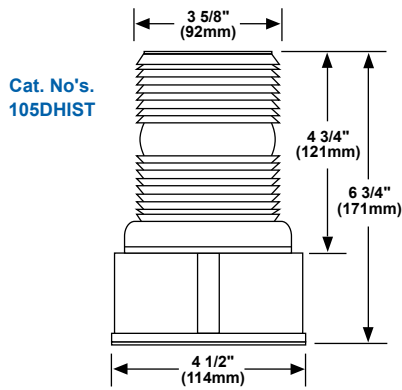

Cat. No. 105BM Mounting Bracket
(use with 105BX)

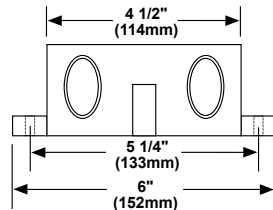

Cat. No. 105BX
Outlet Box Attachment

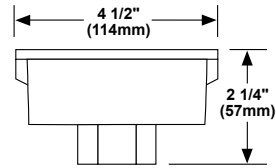

Cat. No. 105PM
Pipe Mount Attachment
(3/4" NPT Conduit Size)