



AC Wire-in Combination Carbon Monoxide & Smoke Alarm

- 120VAC Direct Wire with Battery Backup
- Alarm/Voice message warning system
- Intelligent Sensor Technology

Part Number 900-0114A

Model KN-COSM-IBA

Voice Warning

Warns of hazard by announcing "Fire!" or "Warning, Carbon Monoxide".

Peak Level Memory

Alerts user when the unit has detected CO concentrations of 100ppm or higher.

Hush™ Button

Silences the unit during nuisance alarm situations. (Smoke must be present before hush is activated)

Two LED's

Red LED indicates alarm mode, Green LED indicates AC power is present.

Test/Reset Button Functions

- Tests the units electronics and resets the unit during CO alarm.
- Activates Hush Feature and Peak Level Memory.

Adjustable Mounting Bracket

Allows for easy installation and alignment.

Front Load Battery Door

Replace the 2 AA batteries without disconnecting from mounting bracket.

Alerts user to replace CO alarm after 10 years of operation

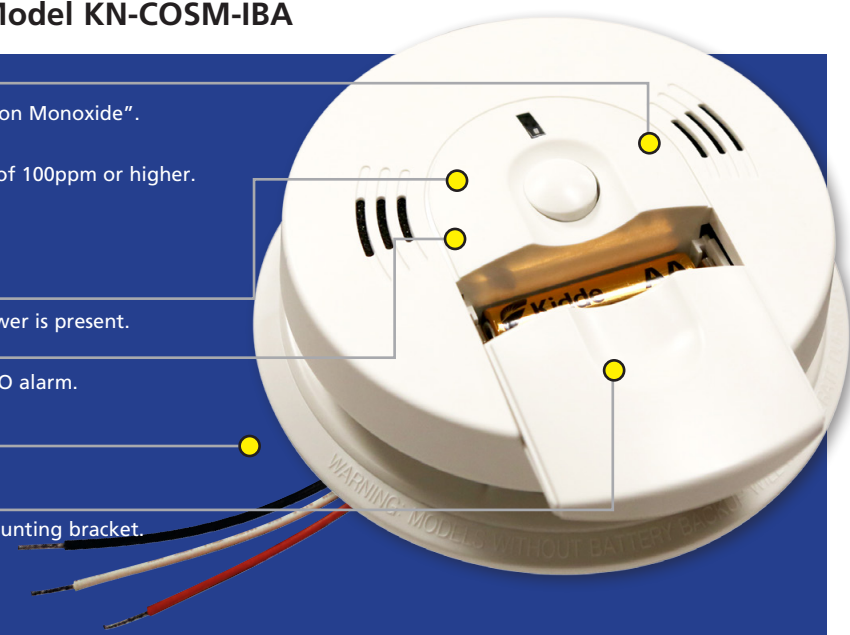

Description

The Kidde 900-0114A uses breakthrough technology to offer a fast response to real fires, including smoldering and fast-flaming, as well as protect you from carbon monoxide and dramatically reduce the chance of nuisance alarms. The Intelligent sensor technology combines the detection capabilities of an ionization smoke sensor – which is more likely to detect smaller, less visible fire particles, like those produced by flaming fires – with that of an electrochemical sensor, which is used to detect CO. Since carbon monoxide is present in all fires, having both detection chambers work together in one alarm is a breakthrough in the fire safety industry. When either sensor notices a potential hazard, it will communicate with the other. Depending on what is detected, the alarm will adjust its smoke sensitivity in order to better discriminate between a real hazard and a false one. This constant communication enhances the alarm's overall performance in all fires, and significantly reduces the potential for a nuisance alarm.

Leading authorities recommend that both ionization and photoelectric smoke alarms be installed to help insure maximum detection of the various types of fires that can occur within the home. Ionization sensing alarms may detect invisible fire particles (associated with fast flaming fires) sooner than photoelectric alarms. Photoelectric sensing alarms may detect visible fire particles (associated with slow smoldering fires) sooner than ionization alarms.

Alarm Warnings

Fire: The red LED will flash and be accompanied by three long alarm beeps followed by a verbal warning message "FIRE!". The alarm pattern will repeat until smoke is eliminated.

Carbon Monoxide: Four short alarm beeps followed by a verbal warning "WARNING! CARBON MONOXIDE!" This continues until the unit is reset or the CO is eliminated.

Low Battery: One chirp followed by warning "LOW BATTERY." The red LED light will flash. This pattern will continue every minute for at least seven days. Under battery power, the "LOW BATTERY" voice only occurs once every 15 minutes.

Voice Hush Indication: "HUSH MODE ACTIVATED" and "HUSH MODE CANCELLED" voice announcement.

Peak Level Memory: If the alarm had detected a CO level of 100ppm or higher when the Test/Reset button is pressed, the unit will announce "CARBON MONOXIDE PREVIOUSLY DETECTED" to warn of the CO incident.

Features and Benefits

- **Smart Interconnect™** – Interconnects up to 24 Kidde devices (of which 18 can be initiating).
- **Battery Backup (2-AA batteries included)** – Provides protection during power outages.
- **Front Loading Battery Door** – Replace the backup batteries without disconnecting from mounting bracket
- **Battery Lockout System** – The battery door will not close unless the batteries are properly installed.
- **Alarm Tamper Resist** – Helps deter from tampering and theft.
- **Adjustable Mounting Bracket** – Makes installation fast and easy. Works with existing smoke and combination smoke and CO mounting brackets.
- **Peak Level Memory** – Announces "CARBON MONOXIDE PREVIOUSLY DETECTED" if alarm has detected a CO level of 100ppm or higher since it was last reset.
- **Hush™ Feature** – Silences nuisance alarms for approximately 9 minutes. (Smoke must be present before Hush™ is activated)
- **Ionization Sensor Technology** – Ideal for detecting fast flaming and other types of fires.
- **Test Button Functions:** – Tests the unit for proper operation – Peak Level memory – Resets the Carbon Monoxide alarm
- **Green LED** – Illuminates to indicate the unit is receiving AC power. Flashes once every 60 seconds to indicate battery only mode. Flashes once per second during alarm to indicate initiating alarm. Flashes once every 16 seconds to indicate smoke or CO previously detected. Flashes every 2 seconds while the alarm is in HUSH™ mode.
- **Red LED** – When a dangerous level of smoke or carbon monoxide is detected the red LED will flash. If the unit malfunctions, the red LED will flash and the unit will chirp every 30 seconds.



Architectural and Engineering Specifications

The combination smoke and carbon monoxide alarm shall be Kidde model KN-COSM-IBA or approved equal. It shall be powered by 120VAC, 60Hz source with two AA battery backup. The temperature operating range shall be between 40°F and 100°F (4°C and 38°C) and the humidity operating range shall be 10% - 95% relative humidity, non-condensing.

The unit shall incorporate an ionization smoke sensor with nominal sensitivity of 0.89%/ft. The CO sensor shall be of a fuel cell design and shall meet the sensitivity requirements of Underwriters Laboratories UL2034 Single and Multiple Station Carbon Monoxide Detectors.

The combination alarm can be installed on the surface of any wall or ceiling following the UL/NFPA/Manufacturer's recommended placement guidelines. The alarm can be installed on any standard single gang electrical box, up to a 4" octagon junction box. The electrical connection (to the alarm) shall be made with a plug-in connector. The unit shall provide optional tamper resistance that deters removal of the unit from the wall or ceiling. No additional pieces shall be required to activate this feature.

A maximum of 24 Kidde devices can be interconnected in a multiple station arrangement. The interconnect system must not exceed the NFPA (National Fire Protection Association) limit of 18 initiating devices, of which 12 can be smoke alarms. With 18 initiating devices (smoke, heat, CO, etc), interconnected, it is still possible to interconnect 6 strobe lights and or relay modules.

The alarm shall include a test button that will electronically simulate the presence of smoke and CO and cause the unit to go into both modes of alarm. This sequence tests the unit's electronics to ensure proper operation.

The CO sensor will not alarm to levels of CO below 30 ppm and will alarm in the following time range when exposed to the corresponding levels of CO.

70 ppm CO Concentration	60 – 240 minutes
150 ppm CO Concentration	10 – 50 minutes
400 ppm CO Concentration	4 – 15 minutes

The combination alarm shall have two methods of warning for danger: a piezoelectric horn that is rated at 85 decibels at 10 feet and a voice warning that identifies the danger. For a CO incident, the horn will sound in the repetitive manner – four (4) fast beeps, a short pause, four (4) fast beeps, a short pause. In between, the unit will announce "Warning Carbon Monoxide!" In a Smoke incident, the horn will sound in the repetitive manner – three (3) beeps, a pause, three (3) beeps, a pause. In between, the unit will announce "FIRE!"

The unit shall incorporate a 2 LED display. A green LED will be steady on when AC power is present, flash every 60 seconds when in battery only mode, every second to indicate alarm memory, and every 2 seconds to indicate the Hush™ mode is active. A red LED will flash in unison with the alarm sounder pattern.

The unit shall include the Hush™ feature that silences the unit for approximately 9 minutes if a nuisance alarm condition occurs. The Green LED on the alarm will flash every 2 seconds while in Hush™ and will automatically reset itself. It also provides voice annunciation of "HUSH MODE ACTIVATED" when Hush™ is activated and "HUSH MODE CANCELLED" when the Hush cycle ends.

The unit shall also indicate a low battery warning utilizing each of the following methods: a brief alarm chirp, the voice announcement of "Low Battery!"

The unit shall at a minimum meet the requirements of UL 2034, UL217, NFPA72, (chapter 11 2002 edition) The State of California Fire Marshall, NFPA101 (One and two family dwellings) Federal Housing Authority (FHA), Housing and Urban Development (HUD). It shall also include a 10-year manufacturer's limited warranty.

Technical Specifications

Power Source:	120VAC, 60Hz 45mA max per alarm 2 AA battery backup
Smoke Sensor:	Ionization
CO Sensor:	Electrochemical
Audio Alarm:	85dB at 10ft
Temperature Range:	40°F (4.4°C) to 100°F (37.8°C)
Humidity Range:	10%-95% relative humidity, non-condensing
Size:	5.6" in diameter x 1.8" depth
Weight:	.75 lb
Wiring:	Quick connect plug with 6" pigtails
Interconnects:	Up to 24 Kidde devices (of which 18 can be initiating)
Warranty:	10 year limited

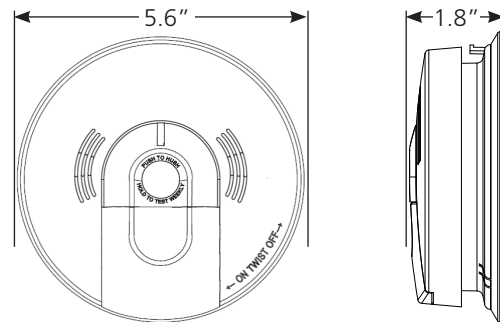

Installation of Smoke Alarm

The combination alarm should be installed to comply with all local codes having jurisdiction in your area, Article 760 of the National Electric Code, and NFPA 72. Make certain all alarms are wired to a single, continuous (non-switched) power line, which is not protected by a ground fault interrupter. A maximum of 1000 ft. of wire can be used in the interconnect system. Use standard UL listed household wire (18 gauge or larger as required by local codes).

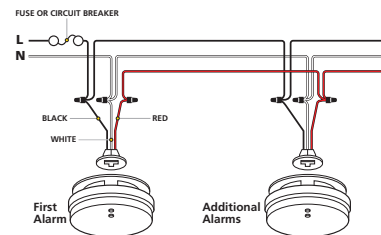

Ordering Information

Ordering Number	UPC	I 2 of 5	Pack Config	Pack Qty	Dimensions (w x d x h inches)	Weight	Cartons/Pallet
21006377-N	0-47871-16377-9	100-47871-16377-6	BOX	Master Pack (6 Units)	6.6 x 13.5 x 6.2	6.7	126
21008495-N	0-47871-18495-8	100-47871-18495-5	CLAM	PDQ (2 Units)	7.8 x 4.5 x 11.8	1.5	180

Distributed by:



1016 Corporate Park Drive
Mebane NC 27302
1-800-880-6788 www.Kidde.com



AC Wire-in Combination Carbon Monoxide & Smoke Alarm

- 120VAC Direct Wire with Battery Backup
- Alarm/Voice message warning system
- Intelligent Sensor Technology

Part Number 900-0114A

Model KN-COSM-IBA

Voice Warning

Warns of hazard by announcing "Fire!" or "Warning, Carbon Monoxide".

Peak Level Memory

Alerts user when the unit has detected CO concentrations of 100ppm or higher.

Hush™ Button

Silences the unit during nuisance alarm situations. (Smoke must be present before hush is activated)

Two LED's

Red LED indicates alarm mode, Green LED indicates AC power is present.

Test/Reset Button Functions

- Tests the units electronics and resets the unit during CO alarm.
- Activates Hush Feature and Peak Level Memory.

Adjustable Mounting Bracket

Allows for easy installation and alignment.

Front Load Battery Door

Replace the 2 AA batteries without disconnecting from mounting bracket.

Alerts user to replace CO alarm after 10 years of operation



Description

The Kidde 900-0114A uses breakthrough technology to offer a fast response to real fires, including smoldering and fast-flaming, as well as protect you from carbon monoxide and dramatically reduce the chance of nuisance alarms. The Intelligent sensor technology combines the detection capabilities of an ionization smoke sensor – which is more likely to detect smaller, less visible fire particles, like those produced by flaming fires – with that of an electrochemical sensor, which is used to detect CO. Since carbon monoxide is present in all fires, having both detection chambers work together in one alarm is a breakthrough in the fire safety industry. When either sensor notices a potential hazard, it will communicate with the other. Depending on what is detected, the alarm will adjust its smoke sensitivity in order to better discriminate between a real hazard and a false one. This constant communication enhances the alarm's overall performance in all fires, and significantly reduces the potential for a nuisance alarm.

Leading authorities recommend that both ionization and photoelectric smoke alarms be installed to help insure maximum detection of the various types of fires that can occur within the home. Ionization sensing alarms may detect invisible fire particles (associated with fast flaming fires) sooner than photoelectric alarms. Photoelectric sensing alarms may detect visible fire particles (associated with slow smoldering fires) sooner than ionization alarms.

Alarm Warnings

Fire: The red LED will flash and be accompanied by three long alarm beeps followed by a verbal warning message "FIRE!". The alarm pattern will repeat until smoke is eliminated.

Carbon Monoxide: Four short alarm beeps followed by a verbal warning "WARNING! CARBON MONOXIDE!" This continues until the unit is reset or the CO is eliminated.

Low Battery: One chirp followed by warning "LOW BATTERY." The red LED light will flash. This pattern will continue every minute for at least seven days. Under battery power, the "LOW BATTERY" voice only occurs once every 15 minutes.

Voice Hush Indication: "HUSH MODE ACTIVATED" and "HUSH MODE CANCELLED" voice announcement.

Peak Level Memory: If the alarm had detected a CO level of 100ppm or higher when the Test/Reset button is pressed, the unit will announce "CARBON MONOXIDE PREVIOUSLY DETECTED" to warn of the CO incident.

Features and Benefits

- **Smart Interconnect™** – Interconnects up to 24 Kidde devices (of which 18 can be initiating).
- **Battery Backup (2-AA batteries included)** – Provides protection during power outages.
- **Front Loading Battery Door** – Replace the backup batteries without disconnecting from mounting bracket
- **Battery Lockout System** – The battery door will not close unless the batteries are properly installed.
- **Alarm Tamper Resist** – Helps deter from tampering and theft.
- **Adjustable Mounting Bracket** – Makes installation fast and easy. Works with existing smoke and combination smoke and CO mounting brackets.
- **Peak Level Memory** – Announces "CARBON MONOXIDE PREVIOUSLY DETECTED" if alarm has detected a CO level of 100ppm or higher since it was last reset.
- **Hush™ Feature** – Silences nuisance alarms for approximately 9 minutes. (Smoke must be present before Hush™ is activated)
- **Ionization Sensor Technology** – Ideal for detecting fast flaming and other types of fires.
- **Test Button Functions:** – Tests the unit for proper operation – Peak Level memory – Resets the Carbon Monoxide alarm
- **Green LED** – Illuminates to indicate the unit is receiving AC power. Flashes once every 60 seconds to indicate battery only mode. Flashes once per second during alarm to indicate initiating alarm. Flashes once every 16 seconds to indicate smoke or CO previously detected. Flashes every 2 seconds while the alarm is in HUSH™ mode.
- **Red LED** – When a dangerous level of smoke or carbon monoxide is detected the red LED will flash. If the unit malfunctions, the red LED will flash and the unit will chirp every 30 seconds.



Architectural and Engineering Specifications

The combination smoke and carbon monoxide alarm shall be Kidde model KN-COSM-IBA or approved equal. It shall be powered by 120VAC, 60Hz source with two AA battery backup. The temperature operating range shall be between 40°F and 100°F (4°C and 38°C) and the humidity operating range shall be 10% - 95% relative humidity, non-condensing.

The unit shall incorporate an ionization smoke sensor with nominal sensitivity of 0.89%/ft. The CO sensor shall be of a fuel cell design and shall meet the sensitivity requirements of Underwriters Laboratories UL2034 Single and Multiple Station Carbon Monoxide Detectors.

The combination alarm can be installed on the surface of any wall or ceiling following the UL/NFPA/Manufacturer's recommended placement guidelines. The alarm can be installed on any standard single gang electrical box, up to a 4" octagon junction box. The electrical connection (to the alarm) shall be made with a plug-in connector. The unit shall provide optional tamper resistance that deters removal of the unit from the wall or ceiling. No additional pieces shall be required to activate this feature.

A maximum of 24 Kidde devices can be interconnected in a multiple station arrangement. The interconnect system must not exceed the NFPA (National Fire Protection Association) limit of 18 initiating devices, of which 12 can be smoke alarms. With 18 initiating devices (smoke, heat, CO, etc), interconnected, it is still possible to interconnect 6 strobe lights and or relay modules.

The alarm shall include a test button that will electronically simulate the presence of smoke and CO and cause the unit to go into both modes of alarm. This sequence tests the unit's electronics to ensure proper operation.

The CO sensor will not alarm to levels of CO below 30 ppm and will alarm in the following time range when exposed to the corresponding levels of CO.

70 ppm CO Concentration	60 – 240 minutes
150 ppm CO Concentration	10 – 50 minutes
400 ppm CO Concentration	4 – 15 minutes

The combination alarm shall have two methods of warning for danger: a piezoelectric horn that is rated at 85 decibels at 10 feet and a voice warning that identifies the danger. For a CO incident, the horn will sound in the repetitive manner – four (4) fast beeps, a short pause, four (4) fast beeps, a short pause. In between, the unit will announce "Warning Carbon Monoxide!" In a Smoke incident, the horn will sound in the repetitive manner – three (3) beeps, a pause, three (3) beeps, a pause. In between, the unit will announce "FIRE!"

The unit shall incorporate a 2 LED display. A green LED will be steady on when AC power is present, flash every 60 seconds when in battery only mode, every second to indicate alarm memory, and every 2 seconds to indicate the Hush™ mode is active. A red LED will flash in unison with the alarm sounder pattern.

The unit shall include the Hush™ feature that silences the unit for approximately 9 minutes if a nuisance alarm condition occurs. The Green LED on the alarm will flash every 2 seconds while in Hush™ and will automatically reset itself. It also provides voice annunciation of "HUSH MODE ACTIVATED" when Hush™ is activated and "HUSH MODE CANCELLED" when the Hush cycle ends.

The unit shall also indicate a low battery warning utilizing each of the following methods: a brief alarm chirp, the voice announcement of "Low Battery!"

The unit shall at a minimum meet the requirements of UL 2034, UL217, NFPA72, (chapter 11 2002 edition) The State of California Fire Marshall, NFPA101 (One and two family dwellings) Federal Housing Authority (FHA), Housing and Urban Development (HUD). It shall also include a 10-year manufacturer's limited warranty.

Technical Specifications

Power Source:	120VAC, 60Hz 45mA max per alarm 2 AA battery backup
Smoke Sensor:	Ionization
CO Sensor:	Electrochemical
Audio Alarm:	85dB at 10ft
Temperature Range:	40°F (4.4°C) to 100°F (37.8°C)
Humidity Range:	10%-95% relative humidity, non-condensing
Size:	5.6" in diameter x 1.8" depth
Weight:	.75 lb
Wiring:	Quick connect plug with 6" pigtails
Interconnects:	Up to 24 Kidde devices (of which 18 can be initiating)
Warranty:	10 year limited

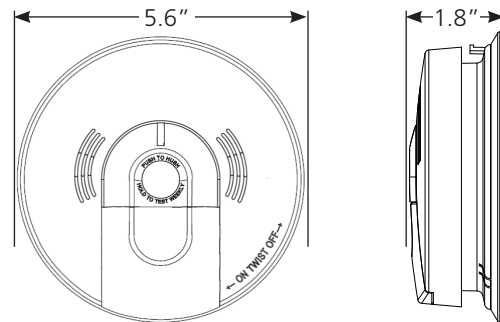

Installation of Smoke Alarm

The combination alarm should be installed to comply with all local codes having jurisdiction in your area, Article 760 of the National Electric Code, and NFPA 72. Make certain all alarms are wired to a single, continuous (non-switched) power line, which is not protected by a ground fault interrupter. A maximum of 1000 ft. of wire can be used in the interconnect system. Use standard UL listed household wire (18 gauge or larger as required by local codes).

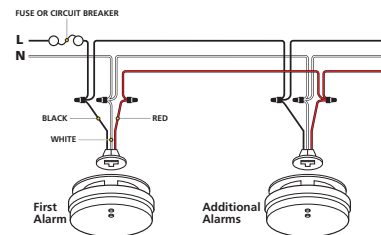

Ordering Information

Ordering Number	UPC	I 2 of 5	Pack Config	Pack Qty	Dimensions (w x d x h inches)	Weight	Cartons/Pallet
21006377-N	0-47871-16377-9	100-47871-16377-6	BOX	Master Pack (6 Units)	6.6 x 13.5 x 6.2	6.7	126
21008495-N	0-47871-18495-8	100-47871-18495-5	CLAM	PDQ (2 Units)	7.8 x 4.5 x 11.8	1.5	180

Distributed by:



1016 Corporate Park Drive
Mebane NC 27302
1-800-880-6788 www.Kidde.com