



# SERVICE PARTS LIST

**BULLETIN NO.**  
54-27-2492

SPECIFY CATALOG NO. AND SERIAL NO. WHEN ORDERING PARTS		REVISED BULLETIN	DATE
<b>M12™ CABLE CUTTER</b>		54-27-2491	May 2016
<b>CATALOG NO.</b>	<b>2472-20</b>	<b>WIRING INSTRUCTION</b>	
<b>SERIAL NUMBER</b>	<b>E21C</b>	<b>See Page 4</b>	

**EXAMPLE:**  
Component Parts (Small #) Are Included  
When Ordering The Assembly (Large #).

FIG.	PART NO.	DESCRIPTION OF PART	NO. REQ.
1	-----	Housing Support	(1)
2	34-40-4480	O-Ring	(1)
3	-----	Switch	(1)
4	42-42-0631	Drive Link Switch Lock-Out	(1)
5	40-50-4520	Spring	(1)
6	44-20-0770	Switch Lock-Out	(1)
7	-----	Housing Cover	(1)
8	10-20-2545	Warning Label	(1)
9	06-82-2385	M2.6 x 14mm Pan Hd. Tapt. T-8 Screw	(2)
10	06-82-7240	6-19 x .5" Pan Hd. Plastite T-15 Screw	(3)
11	06-82-7261	6-19 x .687 Pan Hd. Plastite T-15 Screw	(7)
17	10-20-2675	Jam Release Label	(1)

\* = Part number change from previous service parts list.

SEE PAGE 2 FOR THE EXPLODED VIEW OF THE GEARCASE

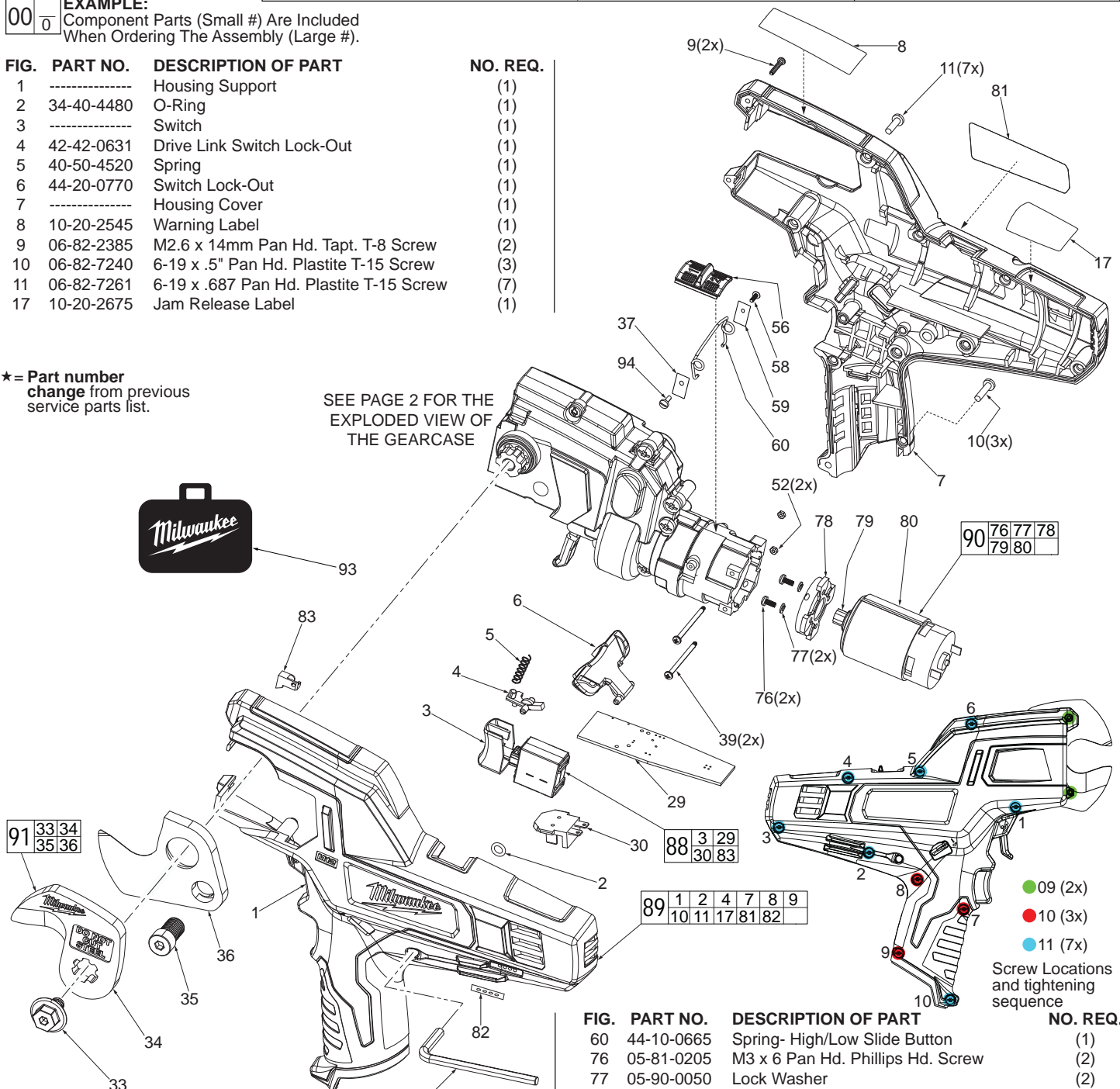

FIG.	PART NO.	DESCRIPTION OF PART	NO. REQ.
29	-----	PCBA	(1)
30	-----	Battery Contact Plate	(1)
32	49-96-0088	3/16" x 3-5/8" Hex Key	(1)
33	42-32-0500	Moving Blade Fitted Bolt with Loctite® Patch	(1)
34	-----	Moving Blade	(1)
35	42-32-0525	Stationary Blade Fixed Bolt w/ Loctite® Patch	(1)
36	-----	Stationary Blade	(1)
37	45-88-8210	Plate Washer with 3.3mm hole	(1)
39	06-81-0485	M2 Pan Hd. Phillips Screw- Motor Mounting	(2)
52	44-40-0115	M2 Hex Nut	(2)
56	45-24-0400	High-Low Slide Button	(1)
58	05-81-0798	M2 Screw	(1)
59	45-88-8205	Plate Washer with 2.3mm hole	(1)

FIG.	PART NO.	DESCRIPTION OF PART	NO. REQ.
60	44-10-0665	Spring- High/Low Slide Button	(1)
76	05-81-0205	M3 x 6 Pan Hd. Phillips Hd. Screw	(2)
77	05-90-0050	Lock Washer	(2)
78	44-66-0995	Motor Mounting Plate	(1)
79	-----	Pinion	(1)
80	-----	Motor	(1)
81	12-20-2465	Service Nameplate	(1)
82	-----	Fuel Gauge Label	(1)
83	-----	LED	(1)
88	23-66-2472	Switch Assembly	(1)
89	31-44-2474	Handle Assembly	(1)
90	23-30-0375	Motor Assembly	(1)
91	48-44-0410	Blade Set	(1)
93	42-55-2472	Carrying Case	(1)
94	05-81-0208	M3 x 6mm Pan Hd. Slotted Screw	(1)

● 09 (2x)  
● 10 (3x)  
● 11 (7x)  
Screw Locations and tightening sequence

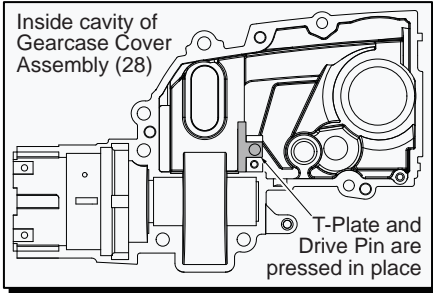
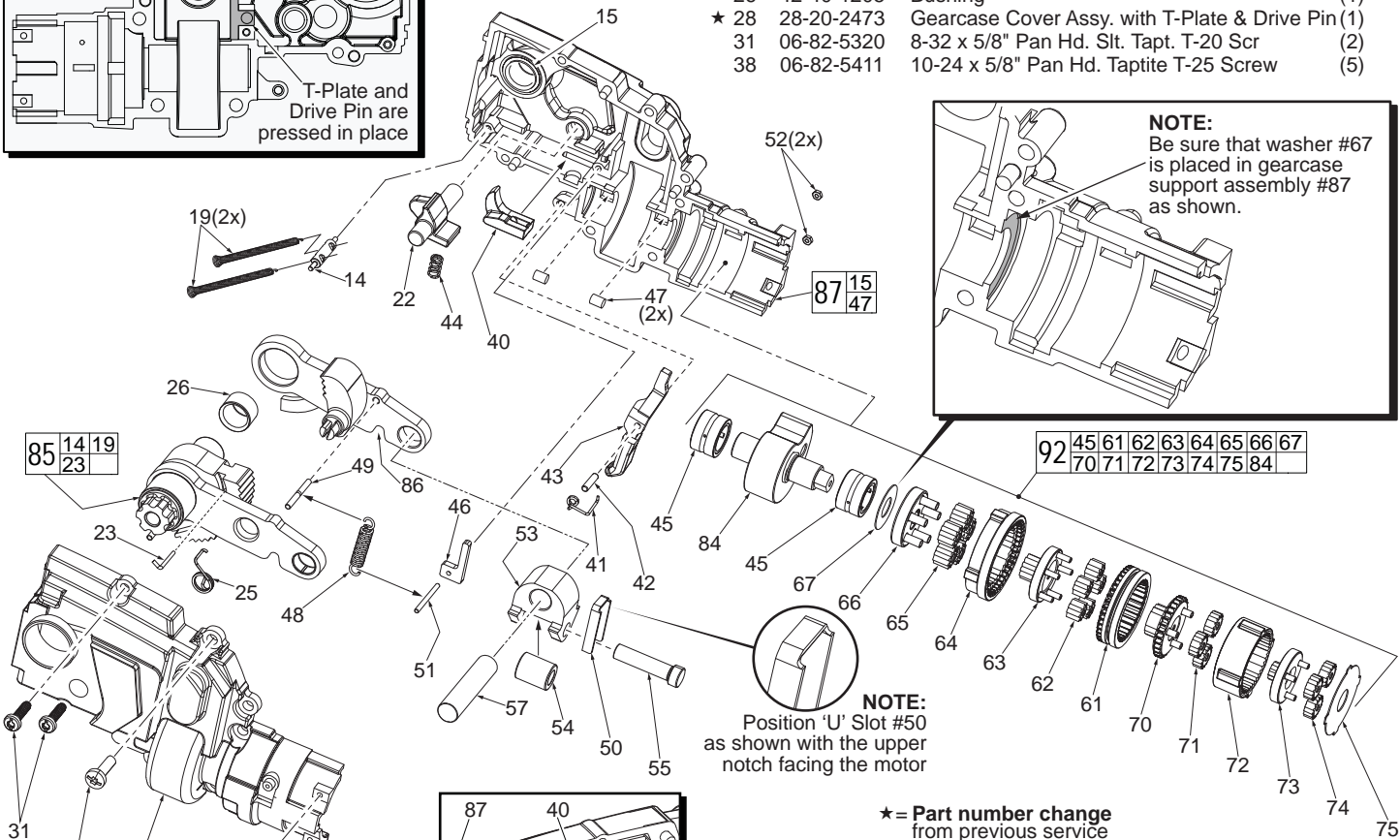
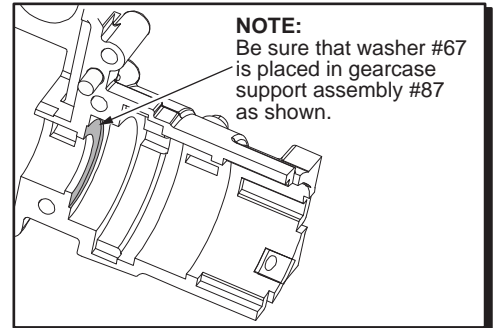
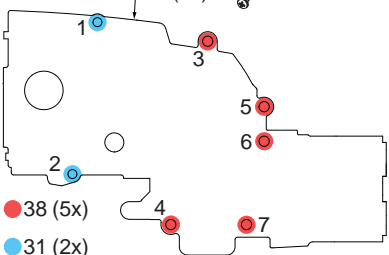

FIG.	PART NO.	DESCRIPTION OF PART	NO. REQ.
14	43-72-0780	Ratchet Spring Holder	(1)
15	-----	Bushing	(1)
19	40-50-1005	Ratchet Return Spring	(2)
22	44-55-0300	Follower Pawl	(1)
23	44-60-1325	Wire Form	(1)
25	40-50-3960	Torsion Spring	(1)
26	42-40-1205	Bushing	(1)
★ 28	28-20-2473	Gearcase Cover Assy. with T-Plate & Drive Pin	(1)
31	06-82-5320	8-32 x 5/8" Pan Hd. Slit. Tapt. T-20 Scr	(2)
38	06-82-5411	10-24 x 5/8" Pan Hd. Taptite T-25 Screw	(5)



★ = Part number change from previous service parts list.



Screw locations and tightening sequence

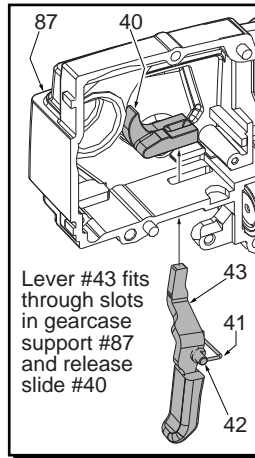
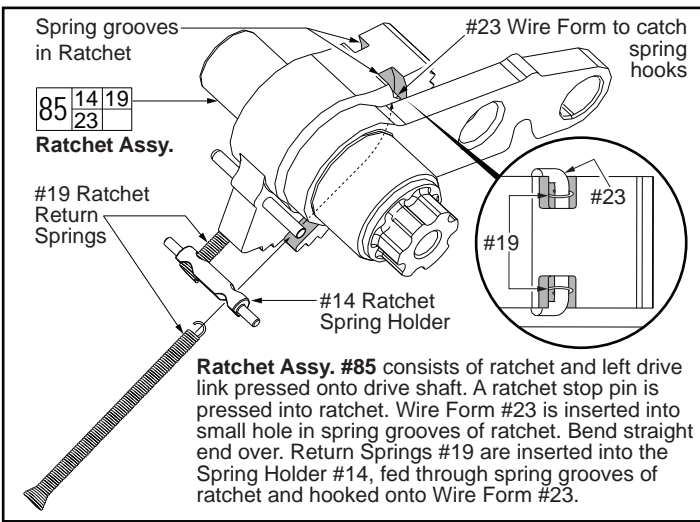

FIG.	PART NO.	DESCRIPTION OF PART	NO. REQ.
39	06-81-0485	M2 Pan Hd. Phillips Screw- Motor Mounting	(2)
40	45-24-1040	Release Slide	(1)
41	40-50-3270	Torsion Spring- Release Lever	(1)
42	44-60-0560	Pin- Release Lever	(1)
43	44-10-0870	Release Lever	(1)
44	40-50-4905	Return Spring- Follower Pawl	(1)
45	02-50-0175	Needle Bearing	(2)
★ 46	44-81-0260	Roller Pin Rail	(1)
47	42-34-5380	Rubber Slug	(2)
48	40-50-3220	Drive Link Return Spring	(1)
49	44-60-2200	Mounting Shaft- Return Spring	(1)
50	28-10-0900	U Slot	(1)
51	44-60-2210	Pin- Drive Link Return Spring	(1)
52	44-40-0115	M2 Hex Nut	(2)
53	43-72-0800	Carrier	(1)
54	44-96-0425	Cam Roller	(1)
55	44-66-2300	Roller Pin	(1)
57	44-66-2310	Roller Carrier Pin	(1)
61	-----	3rd Stage Ring Gear	(1)
62	-----	3rd Stage Planet Gear	(5)
63	-----	4th Stage Sun Gear	(1)
64	-----	4th Stage Ring Gear	(1)
65	-----	4th Stage Planet Gear	(5)
66	-----	4th Stage Carrier	(1)
67	-----	Washer	(1)
70	-----	3rd Stage Sun Gear	(1)
71	-----	2nd Stage Planet Gear	(3)
72	-----	1st and 2nd Stage Ring Gear	(1)
73	-----	2nd Stage Sun Gear	(1)
74	-----	1st Stage Planet Gear	(3)
75	-----	Motor Spacer Plate	(1)
84	42-50-0600	Cam and Cam Shaft Assembly	(1)
★ 85	44-84-0381	Drive Shaft/Link/Ratchet Assembly	(1)
★ 86	44-55-0351	Drive Pawl/Link/Release Lever Assembly	(1)
★ 87	28-14-0496	Gearcase Support Assembly	(1)
92	14-29-0800	Gear/Cam Assembly	(1)



## LUBRICATION NOTES:

● Type 'L' Grease  
No. 49-08-4175, 1 lbs. can

● Type 'P' Grease  
No. 49-08-4250, 1-1/2 oz. tube

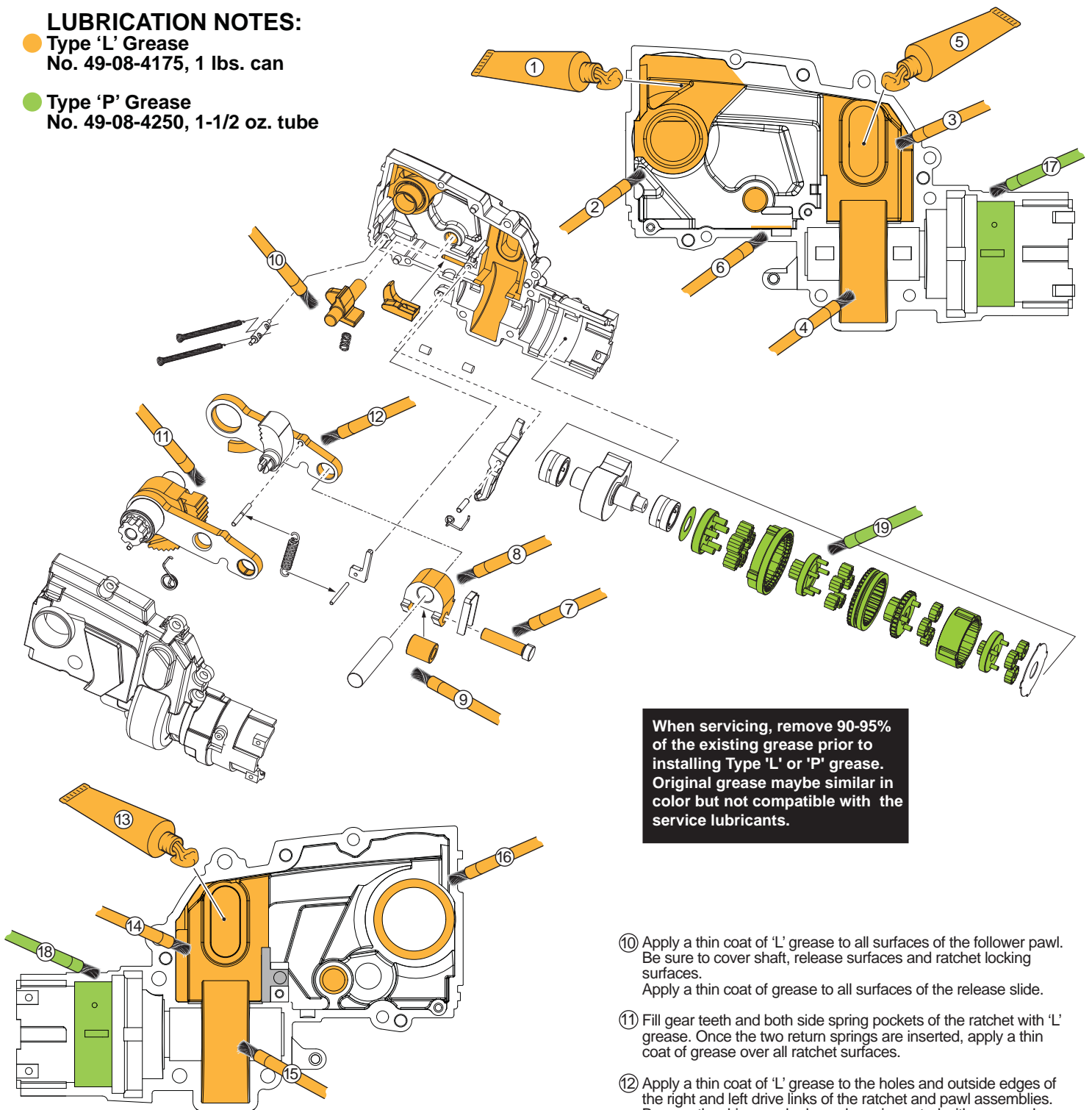

When servicing, remove 90-95% of the existing grease prior to installing Type 'L' or 'P' grease. Original grease may be similar in color but not compatible with the service lubricants.

- ① Place 5 grams (approx. 3/16 ounce) of Type 'L' grease in the upper left corner of gearcase support assembly.
- ② Apply a thin coat of 'L' grease around and in the drive shaft bushing.
- ③ Apply a thin coat of 'L' grease to area shown. Be sure to cover the roller carrier slot and the surfaces the roller pin will have contact with.
- ④ Coat the cam pocket of the gearcase support with 'L' grease.
- ⑤ Place 5 grams (3/16 ounce) of 'L' grease in carrier pin pocket.
- ⑥ Coat the release slide slot in gearcase support with 'L' grease.
- ⑦ Apply a thin coat of 'L' grease to the roller pin prior to assembly with the carrier and roller.
- ⑧ Coat the top and bottom surfaces of the carrier with 'L' grease.
- ⑨ After assembly in the carrier with the pin, add 3 grams (approx. 1/8 oz.) of 'L' grease to the surface of the roller.

- ⑩ Apply a thin coat of 'L' grease to all surfaces of the follower pawl. Be sure to cover shaft, release surfaces and ratchet locking surfaces. Apply a thin coat of grease to all surfaces of the release slide.
- ⑪ Fill gear teeth and both side spring pockets of the ratchet with 'L' grease. Once the two return springs are inserted, apply a thin coat of grease over all ratchet surfaces.
- ⑫ Apply a thin coat of 'L' grease to the holes and outside edges of the right and left drive links of the ratchet and pawl assemblies. Be sure the drive pawl release lever is coated with grease also.
- ⑬ Place 5 grams (3/16 ounce) of 'L' grease in carrier pin pocket.
- ⑭ Apply a thin coat of 'L' grease to area shown. Be sure to cover the roller carrier slot and the surfaces the roller pin will have contact with.
- ⑮ Coat the cam pocket of the gearcase support with 'L' grease.
- ⑯ Place a thin layer of 'L' grease to the inside walls of the gearcase cover bushing and follower pawl shaft hole. Apply a thin coat of grease to the area outside the bushing.
- ⑰ Apply a thin coat of Type 'P' grease to the ring gear pocket of the gearcase support assembly.
- ⑱ Apply a thin coat of Type 'P' grease to the ring gear pocket of the gearcase cover.
- ⑲ Place a thin coat of 'P' grease to the gear components shown above. Be sure that all ring gear teeth and planetary gear teeth are completely covered.

**MOTOR WIRING**

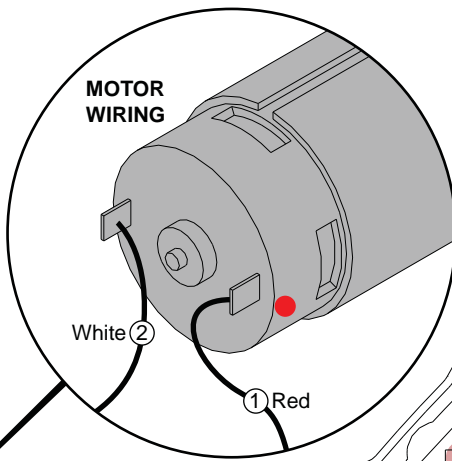

AS AN AID TO REASSEMBLY, TAKE NOTICE OF WIRE ROUTING AND POSITION IN WIRE GUIDES AND TRAPS WHILE DISMANTLING TOOL.

BE CAREFUL AND AVOID PINCHING WIRES BETWEEN HANDLE HALVES / BUSHINGS WHEN ASSEMBLING.

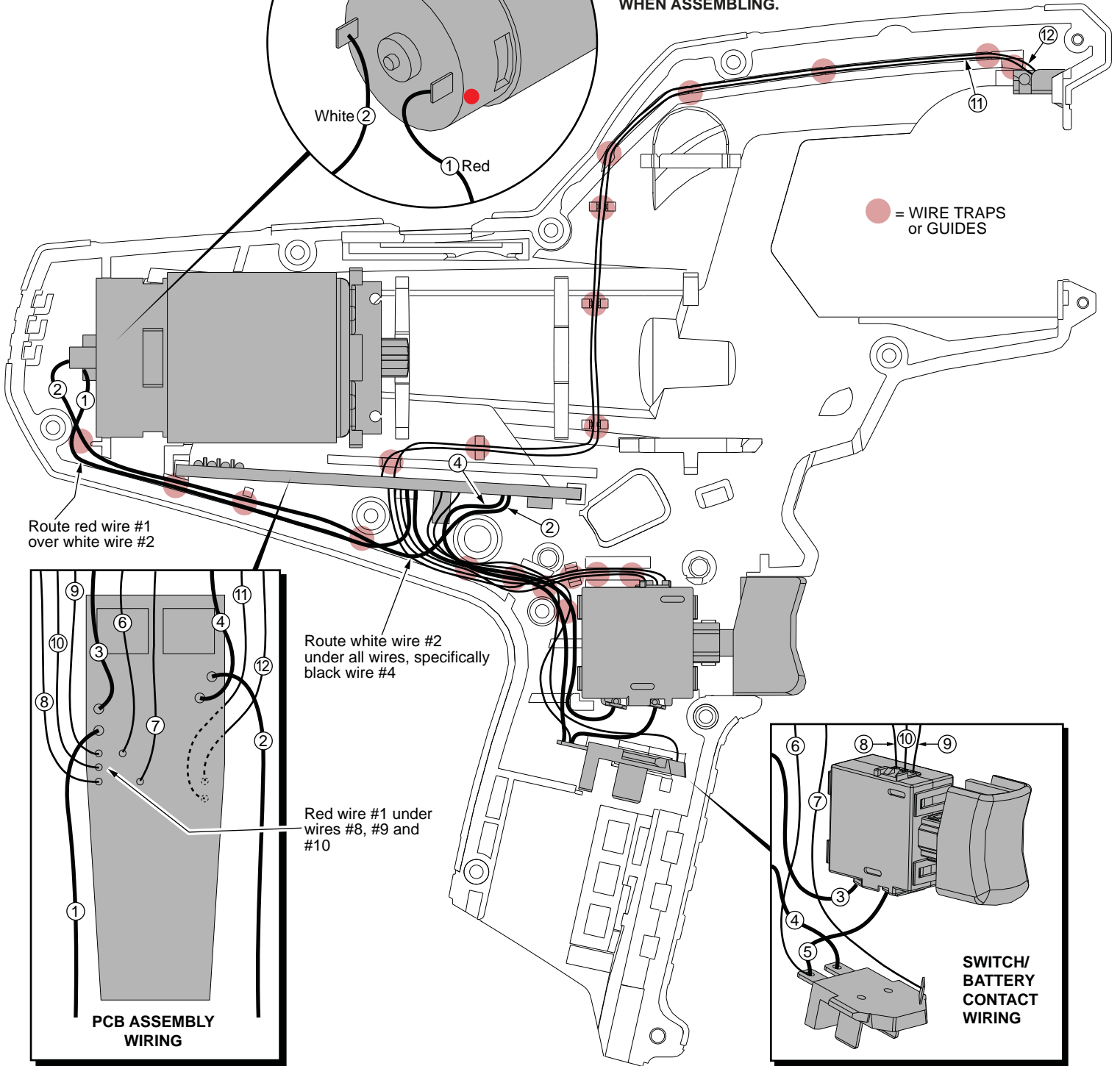

● = WIRE TRAPS or GUIDES

Route red wire #1 over white wire #2

Route white wire #2 under all wires, specifically black wire #4

Red wire #1 under wires #8, #9 and #10

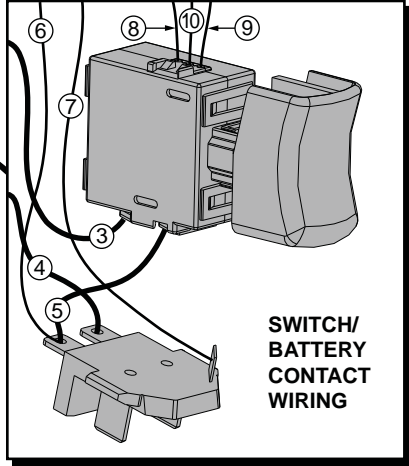
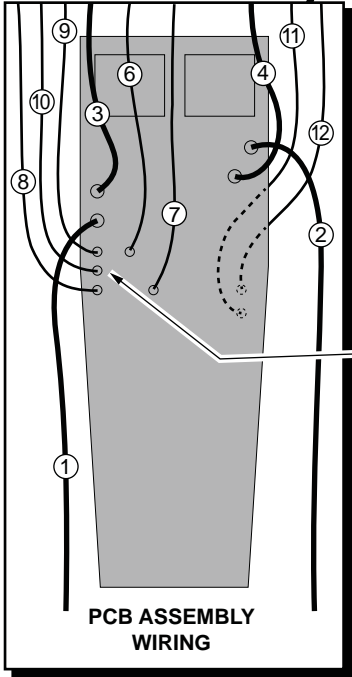

- |          |   |         |                     |
|----------|---|---------|---------------------|
| ① RED    | PCB to motor positive (MTR+)              | ⑨ BLACK | PCB to switch (blk) |
| ② WHITE  | PCB to motor negative (MTR-)              | ⑩ BLUE  | PCB to switch (blu) |
| ③ RED    | PCB to switch (B+ SW)                     | ⑪ BLACK | PCB to LED (LED-)   |
| ④ BLACK  | PCB to negative battery contact (BAT-)    | ⑫ BLUE  | PCB to LED (LED+)   |
| ⑤ RED    | Switch to positive battery contact (BAT+) |         |                     |
| ⑥ RED    | PCB to battery contact (BAT+)             |         |                     |
| ⑦ WHITE  | PCB to battery contact (BAT_ther)         |         |                     |
| ⑧ YELLOW | PCB to switch (ylw)                       |         |                     |



# SERVICE PARTS LIST

**BULLETIN NO.**  
54-27-2492

SPECIFY CATALOG NO. AND SERIAL NO. WHEN ORDERING PARTS				REVISED BULLETIN	DATE
<b>M12™ CABLE CUTTER</b>				54-27-2491	May 2016
				WIRING INSTRUCTION	
<b>CATALOG NO.</b>	<b>2472-20</b>	<b>SERIAL NUMBER</b>	<b>E21C</b>		

**EXAMPLE:**  
Component Parts (Small #) Are Included  
When Ordering The Assembly (Large #).

FIG.	PART NO.	DESCRIPTION OF PART	NO. REQ.
1	-----	Housing Support	(1)
2	34-40-4480	O-Ring	(1)
3	-----	Switch	(1)
4	42-42-0631	Drive Link Switch Lock-Out	(1)
5	40-50-4520	Spring	(1)
6	44-20-0770	Switch Lock-Out	(1)
7	-----	Housing Cover	(1)
8	10-20-2545	Warning Label	(1)
9	06-82-2385	M2.6 x 14mm Pan Hd. Tapt. T-8 Screw	(2)
10	06-82-7240	6-19 x .5" Pan Hd. Plastite T-15 Screw	(3)
11	06-82-7261	6-19 x .687 Pan Hd. Plastite T-15 Screw	(7)
17	10-20-2675	Jam Release Label	(1)

\* = Part number change from previous service parts list.

SEE PAGE 2 FOR THE EXPLODED VIEW OF THE GEARCASE

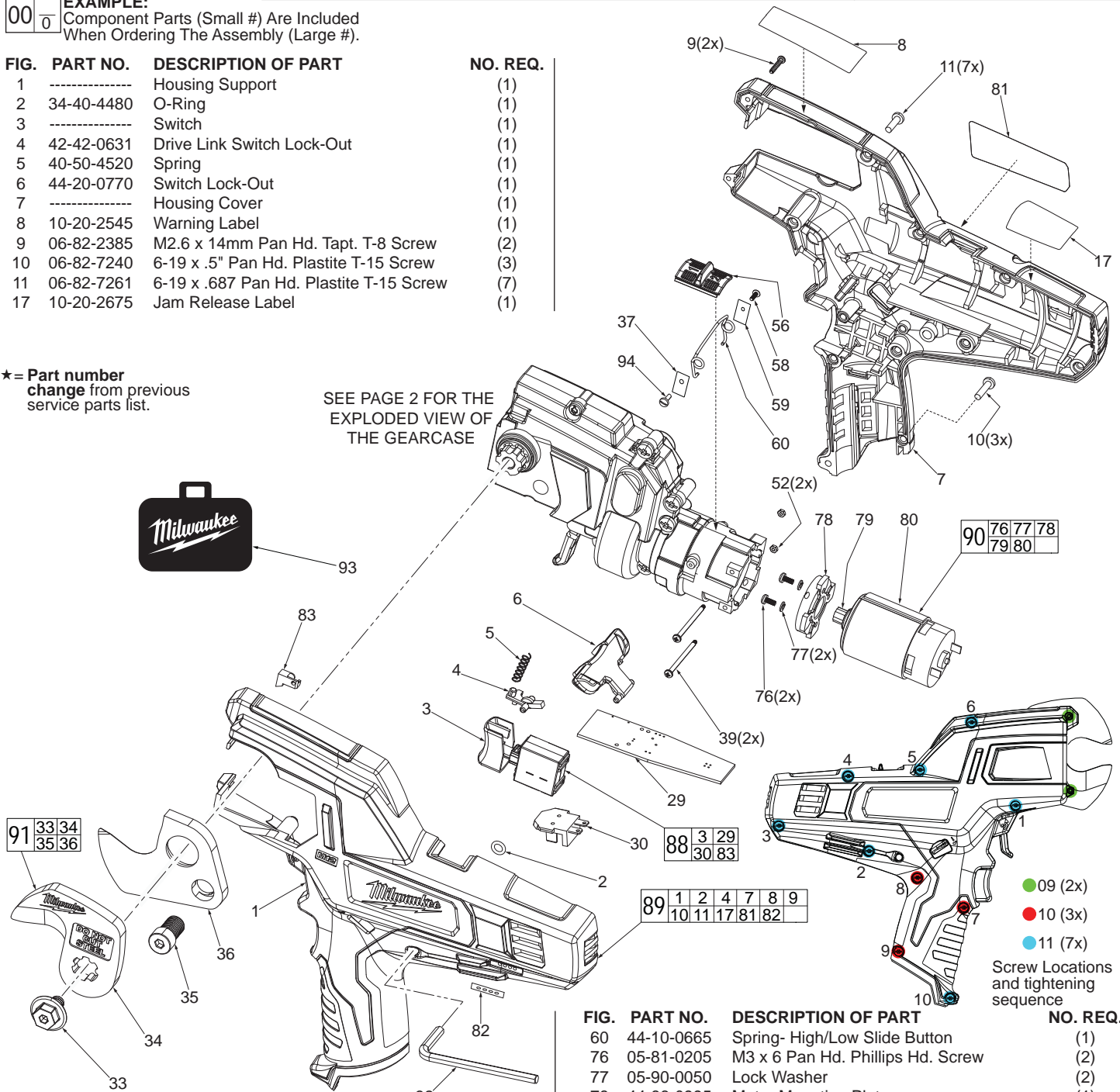

FIG.	PART NO.	DESCRIPTION OF PART	NO. REQ.
29	-----	PCBA	(1)
30	-----	Battery Contact Plate	(1)
32	49-96-0088	3/16" x 3-5/8" Hex Key	(1)
33	42-32-0500	Moving Blade Fitted Bolt with Loctite® Patch	(1)
34	-----	Moving Blade	(1)
35	42-32-0525	Stationary Blade Fixed Bolt w/ Loctite® Patch	(1)
36	-----	Stationary Blade	(1)
37	45-88-8210	Plate Washer with 3.3mm hole	(1)
39	06-81-0485	M2 Pan Hd. Phillips Screw- Motor Mounting	(2)
52	44-40-0115	M2 Hex Nut	(2)
56	45-24-0400	High-Low Slide Button	(1)
58	05-81-0798	M2 Screw	(1)
59	45-88-8205	Plate Washer with 2.3mm hole	(1)

FIG.	PART NO.	DESCRIPTION OF PART	NO. REQ.
60	44-10-0665	Spring- High/Low Slide Button	(1)
76	05-81-0205	M3 x 6 Pan Hd. Phillips Hd. Screw	(2)
77	05-90-0050	Lock Washer	(2)
78	44-66-0995	Motor Mounting Plate	(1)
79	-----	Pinion	(1)
80	-----	Motor	(1)
81	12-20-2465	Service Nameplate	(1)
82	-----	Fuel Gauge Label	(1)
83	-----	LED	(1)
88	23-66-2472	Switch Assembly	(1)
89	31-44-2474	Handle Assembly	(1)
90	23-30-0375	Motor Assembly	(1)
91	48-44-0410	Blade Set	(1)
93	42-55-2472	Carrying Case	(1)
94	05-81-0208	M3 x 6mm Pan Hd. Slotted Screw	(1)

● 09 (2x)  
● 10 (3x)  
● 11 (7x)  
Screw Locations and tightening sequence

**MILWAUKEE ELECTRIC TOOL CORPORATION**  
13135 W. LISBON RD., BROOKFIELD, WI 53005  
Drwg. 1

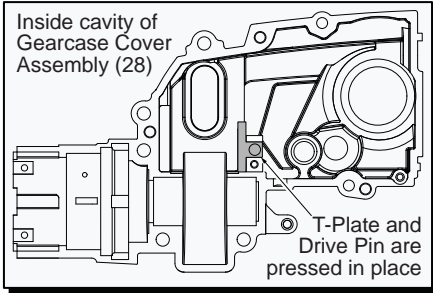
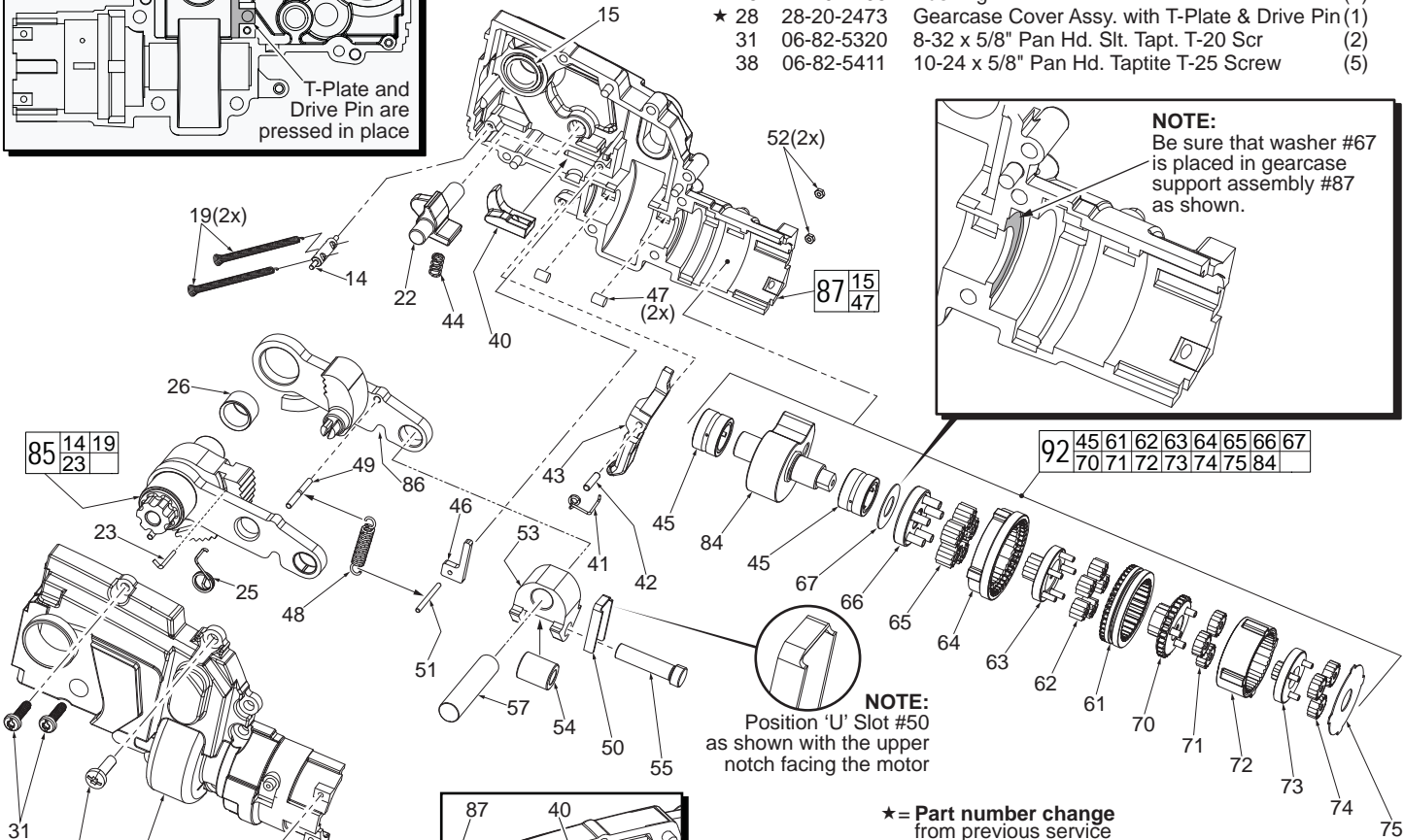
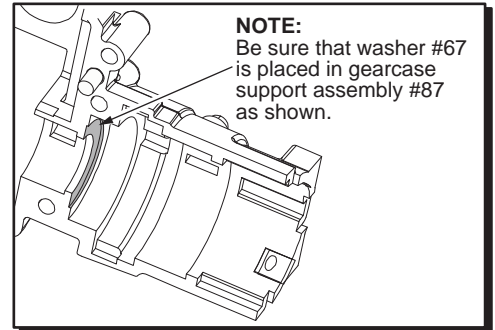
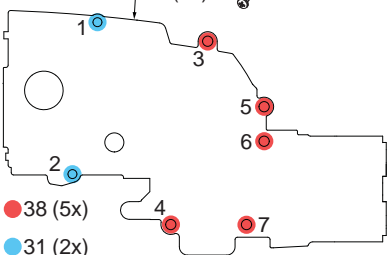

FIG.	PART NO.	DESCRIPTION OF PART	NO. REQ.
14	43-72-0780	Ratchet Spring Holder	(1)
15	-----	Bushing	(1)
19	40-50-1005	Ratchet Return Spring	(2)
22	44-55-0300	Follower Pawl	(1)
23	44-60-1325	Wire Form	(1)
25	40-50-3960	Torsion Spring	(1)
26	42-40-1205	Bushing	(1)
★ 28	28-20-2473	Gearcase Cover Assy. with T-Plate & Drive Pin	(1)
31	06-82-5320	8-32 x 5/8" Pan Hd. Slit. Tapt. T-20 Scr	(2)
38	06-82-5411	10-24 x 5/8" Pan Hd. Taptite T-25 Screw	(5)



★ = Part number change from previous service parts list.



Screw locations and tightening sequence

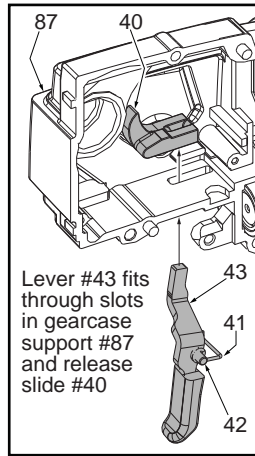
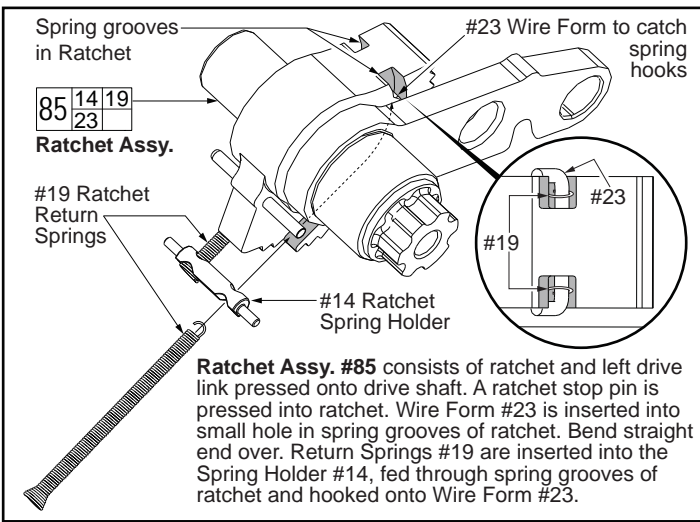

FIG.	PART NO.	DESCRIPTION OF PART	NO. REQ.
39	06-81-0485	M2 Pan Hd. Phillips Screw- Motor Mounting	(2)
40	45-24-1040	Release Slide	(1)
41	40-50-3270	Torsion Spring- Release Lever	(1)
42	44-60-0560	Pin- Release Lever	(1)
43	44-10-0870	Release Lever	(1)
44	40-50-4905	Return Spring- Follower Pawl	(1)
45	02-50-0175	Needle Bearing	(2)
★ 46	44-81-0260	Roller Pin Rail	(1)
47	42-34-5380	Rubber Slug	(2)
48	40-50-3220	Drive Link Return Spring	(1)
49	44-60-2200	Mounting Shaft- Return Spring	(1)
50	28-10-0900	U Slot	(1)
51	44-60-2210	Pin- Drive Link Return Spring	(1)
52	44-40-0115	M2 Hex Nut	(2)
53	43-72-0800	Carrier	(1)
54	44-96-0425	Cam Roller	(1)
55	44-66-2300	Roller Pin	(1)
57	44-66-2310	Roller Carrier Pin	(1)
61	-----	3rd Stage Ring Gear	(1)
62	-----	3rd Stage Planet Gear	(5)
63	-----	4th Stage Sun Gear	(1)
64	-----	4th Stage Ring Gear	(1)
65	-----	4th Stage Planet Gear	(5)
66	-----	4th Stage Carrier	(1)
67	-----	Washer	(1)
70	-----	3rd Stage Sun Gear	(1)
71	-----	2nd Stage Planet Gear	(3)
72	-----	1st and 2nd Stage Ring Gear	(1)
73	-----	2nd Stage Sun Gear	(1)
74	-----	1st Stage Planet Gear	(3)
75	-----	Motor Spacer Plate	(1)
84	42-50-0600	Cam and Cam Shaft Assembly	(1)
★ 85	44-84-0381	Drive Shaft/Link/Ratchet Assembly	(1)
★ 86	44-55-0351	Drive Pawl/Link/Release Lever Assembly	(1)
★ 87	28-14-0496	Gearcase Support Assembly	(1)
92	14-29-0800	Gear/Cam Assembly	(1)



## LUBRICATION NOTES:

● Type 'L' Grease  
No. 49-08-4175, 1 lbs. can

● Type 'P' Grease  
No. 49-08-4250, 1-1/2 oz. tube

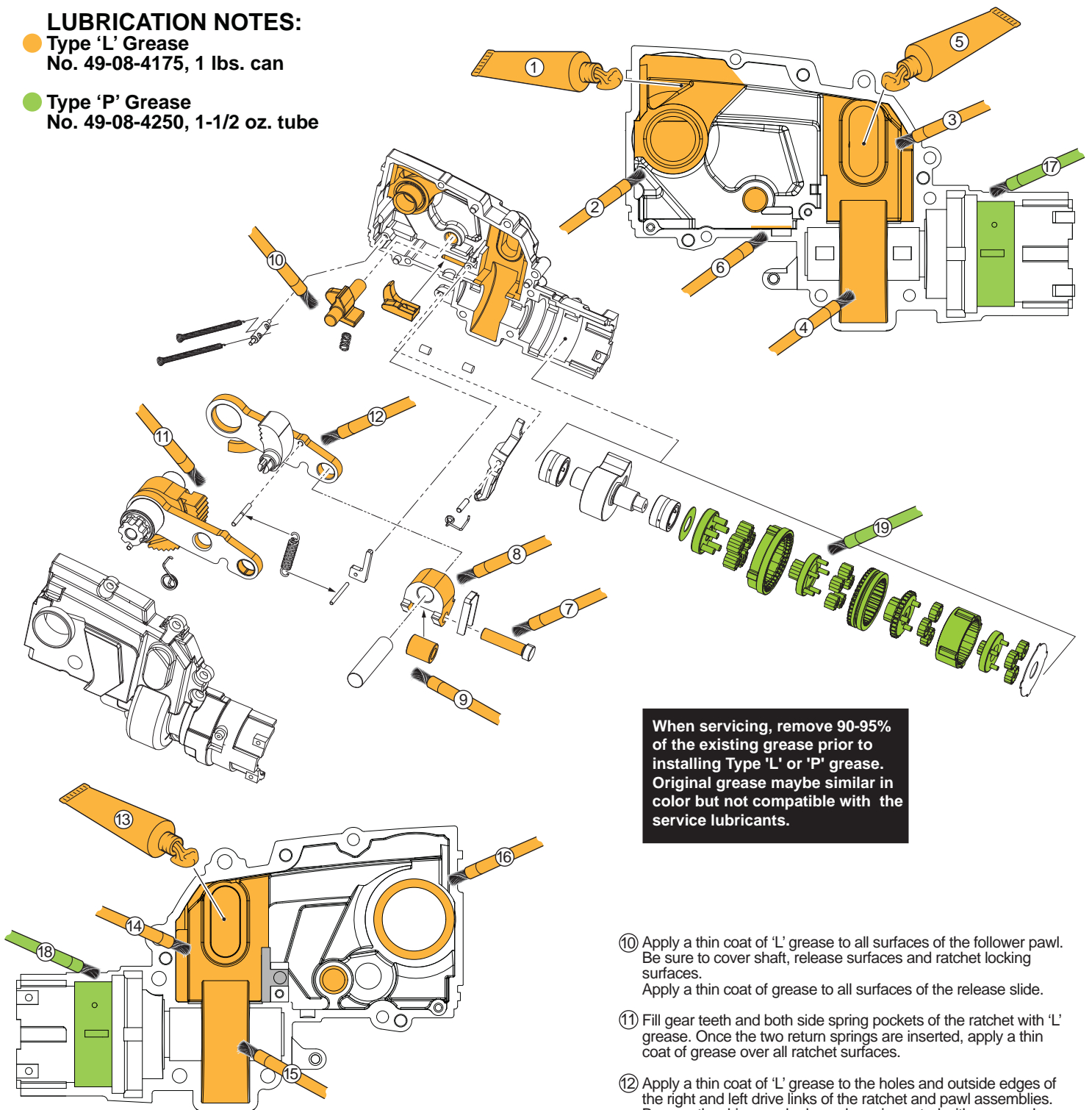

When servicing, remove 90-95% of the existing grease prior to installing Type 'L' or 'P' grease. Original grease may be similar in color but not compatible with the service lubricants.

- ① Place 5 grams (approx. 3/16 ounce) of Type 'L' grease in the upper left corner of gearcase support assembly.
- ② Apply a thin coat of 'L' grease around and in the drive shaft bushing.
- ③ Apply a thin coat of 'L' grease to area shown. Be sure to cover the roller carrier slot and the surfaces the roller pin will have contact with.
- ④ Coat the cam pocket of the gearcase support with 'L' grease.
- ⑤ Place 5 grams (3/16 ounce) of 'L' grease in carrier pin pocket.
- ⑥ Coat the release slide slot in gearcase support with 'L' grease.
- ⑦ Apply a thin coat of 'L' grease to the roller pin prior to assembly with the carrier and roller.
- ⑧ Coat the top and bottom surfaces of the carrier with 'L' grease.
- ⑨ After assembly in the carrier with the pin, add 3 grams (approx. 1/8 oz.) of 'L' grease to the surface of the roller.

- ⑩ Apply a thin coat of 'L' grease to all surfaces of the follower pawl. Be sure to cover shaft, release surfaces and ratchet locking surfaces. Apply a thin coat of grease to all surfaces of the release slide.
- ⑪ Fill gear teeth and both side spring pockets of the ratchet with 'L' grease. Once the two return springs are inserted, apply a thin coat of grease over all ratchet surfaces.
- ⑫ Apply a thin coat of 'L' grease to the holes and outside edges of the right and left drive links of the ratchet and pawl assemblies. Be sure the drive pawl release lever is coated with grease also.
- ⑬ Place 5 grams (3/16 ounce) of 'L' grease in carrier pin pocket.
- ⑭ Apply a thin coat of 'L' grease to area shown. Be sure to cover the roller carrier slot and the surfaces the roller pin will have contact with.
- ⑮ Coat the cam pocket of the gearcase support with 'L' grease.
- ⑯ Place a thin layer of 'L' grease to the inside walls of the gearcase cover bushing and follower pawl shaft hole. Apply a thin coat of grease to the area outside the bushing.
- ⑰ Apply a thin coat of Type 'P' grease to the ring gear pocket of the gearcase support assembly.
- ⑱ Apply a thin coat of Type 'P' grease to the ring gear pocket of the gearcase cover.
- ⑲ Place a thin coat of 'P' grease to the gear components shown above. Be sure that all ring gear teeth and planetary gear teeth are completely covered.

**MOTOR WIRING**

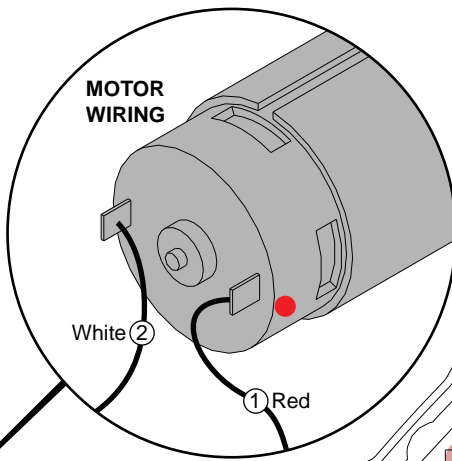

AS AN AID TO REASSEMBLY, TAKE NOTICE OF WIRE ROUTING AND POSITION IN WIRE GUIDES AND TRAPS WHILE DISMANTLING TOOL.

BE CAREFUL AND AVOID PINCHING WIRES BETWEEN HANDLE HALVES / BUSHINGS WHEN ASSEMBLING.

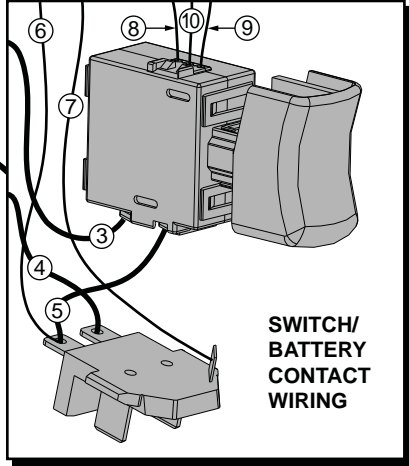
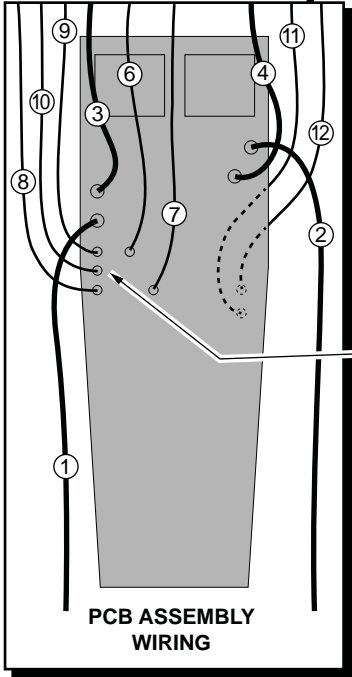
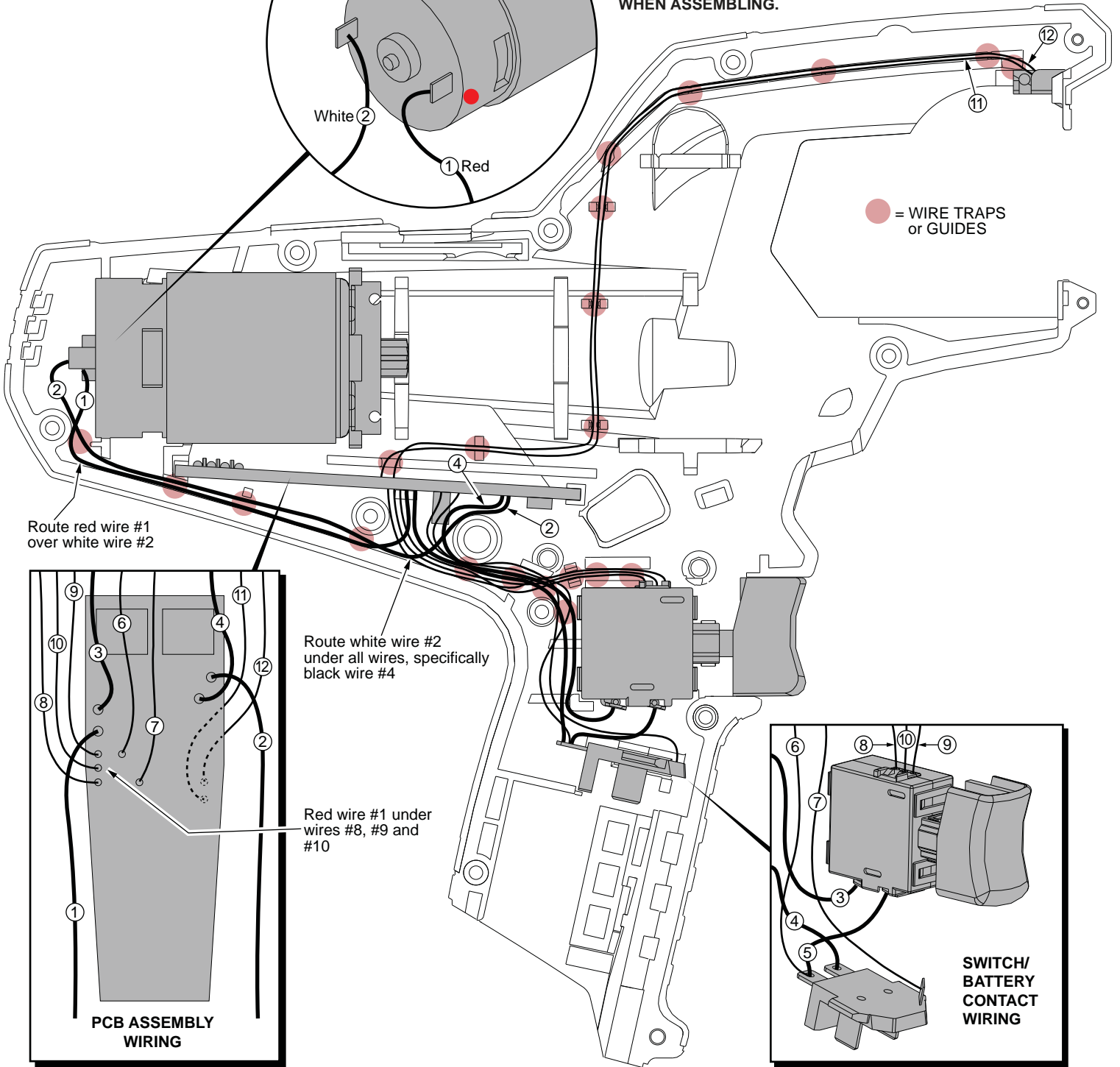

- |          |   |         |                     |
|----------|---|---------|---------------------|
| ① RED    | PCB to motor positive (MTR+)              | ⑨ BLACK | PCB to switch (blk) |
| ② WHITE  | PCB to motor negative (MTR-)              | ⑩ BLUE  | PCB to switch (blu) |
| ③ RED    | PCB to switch (B+ SW)                     | ⑪ BLACK | PCB to LED (LED-)   |
| ④ BLACK  | PCB to negative battery contact (BAT-)    | ⑫ BLUE  | PCB to LED (LED+)   |
| ⑤ RED    | Switch to positive battery contact (BAT+) |         |                     |
| ⑥ RED    | PCB to battery contact (BAT+)             |         |                     |
| ⑦ WHITE  | PCB to battery contact (BAT_ther)         |         |                     |
| ⑧ YELLOW | PCB to switch (ylw)                       |         |                     |