



SERVICE PARTS LIST

BULLETIN NO.
54-38-2683

SPECIFY CATALOG NO. AND SERIAL NO. WHEN ORDERING PARTS		REVISED BULLETIN 54-38-2682	DATE Nov. 2016
CORDLESS 18 VOLT 4-1/2" CUT-OFF/GRINDER		WIRING INSTRUCTION SEE PAGE 2	
CATALOG NO.	2680-20	STARTING SERIAL NO.	B96D

EXAMPLE:
Component Parts (Small #) Are Included
When Ordering The Assembly (Large #).

★ = Part number change from
previous service parts list.

FIG. LUBRICATION:
(Use Type 'Y' grease, No. 49-08-5270)

10 Apply a thin coat of grease to the
Spindle Hub O-Ring.

13,38 Apply grease to all teeth of the
Pinion and Gear.

27 Place 1/8 oz. grease in Gearcase
cavity.

32,33 Apply a thin coat of grease between
Spindle Lock Shaft and O-Ring.

Functionally check the Spindle Lock
mechanism. Spindle Lock must
return briskly when released
from engagement in
Gear (13).

FIG.	PART NO.	DESCRIPTION OF PART	NO. REQ.
1	05-78-5316	M4 x 14mm Pan Hd. Tapt. T-20 Screw	(4)
2	05-88-1200	M4 x 16 T-20 Screw	(9)
3	06-82-7236	4-20 x 5/8" Pan Hd. Plast. T-10 Screw	(1)
4	05-90-0225	Split Washer	(4)
5	14-34-0900	Handle Kit	(1)
6	-----	Right Handle Halve	(1)
7	-----	Left Handle Halve	(1)
★ 8	-----	Spindle Shaft	(1)
9	-----	Spindle Hub	(1)
10	34-40-0560	O-Ring	(1)
11	-----	Ball Bearing	(1)
12	34-80-2275	Internal Snap Ring	(1)
★ 13	-----	Gear	(1)
14	40-50-1090	Spring	(1)
15	22-09-1350	Electronics Module Assembly	(1)
★ 17	32-05-0121	Spindle Shaft/Gear Assembly	(1)
18	23-68-2875	Switch Assembly	(1)
19	-----	Brush Card	(1)
20	31-92-0530	Paddle Trigger Assembly	(1)
21	-----	Paddle Trigger	(1)
22	42-42-0620	Lock-Off Lever	(1)
23	40-50-1480	Spring	(1)
24	06-65-0450	Roll Pin	(1)
★ 25	14-30-0852	Gearcase Kit	(1)
★ 26	28-14-2452	Gearcase Assembly	(1)
27	-----	Gearcase	(1)
★ 28	-----	Shaft Bushing	(1)
29	42-42-1100	Spindle Lock Button	(1)
30	40-50-1330	Spring	(1)
31	42-42-0580	Spindle Lock Tube	(1)
32	44-60-1690	Spindle Lock Pin	(1)
33	34-40-0450	O-Ring	(1)
★ 34	16-01-0061	Armature Assembly	(1)
36	-----	Bearing Retainer	(1)
★ 37	-----	Ball Bearing	(1)
★ 38	-----	Pinion	(1)
39	45-36-2040	Armature Spacer	(3)
40	02-04-1875	Ball Bearing	(1)
41	18-01-3025	Service Field	(1)
42	43-34-0036	Disk Flange	(1)
43	44-40-0035	Flange Nut	(1)
44	12-20-2490	Service Nameplate Kit	(1)
60	43-54-1070	4.5" T27 Guard Assembly	(1)
61	43-54-1090	4.5" T1 Guard Assembly	(1)
72	05-88-0928	M3 x 5mm Pan Hd. T10 Screw	(2)
73	45-88-1980	Spring Washer	(2)
74	-----	Leadwire Assembly - Red	(1)
75	-----	Leadwire Assembly - Black	(1)
76	14-46-2396	Leadwire/Screw/Washer Kit	(1)
77	14-46-2014	Brush Card Assembly	(1)
	42-62-0105	Side Handle (Not Shown)	(1)
	49-96-7215	Spanner Wrench (Not Shown)	(1)

FIG. NOTES:
28 Assemble Needle Bearing with vendor I.D. facing the Gear.

37 Assemble Ball Bearing with seal towards Pinion and shield
towards Armature.

AS AN AID TO REASSEMBLY, TAKE NOTICE OF WIRE ROUTING AND POSITION IN WIRE GUIDES AND TRAPS WHILE DISMANTLING TOOL.

PC BOARD
(Component of the Electronics Module Assembly)

⑧ BLACK
(From Terminal Block to PCB)

SWITCH ASSEMBLY

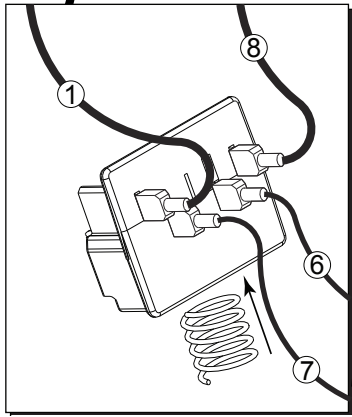
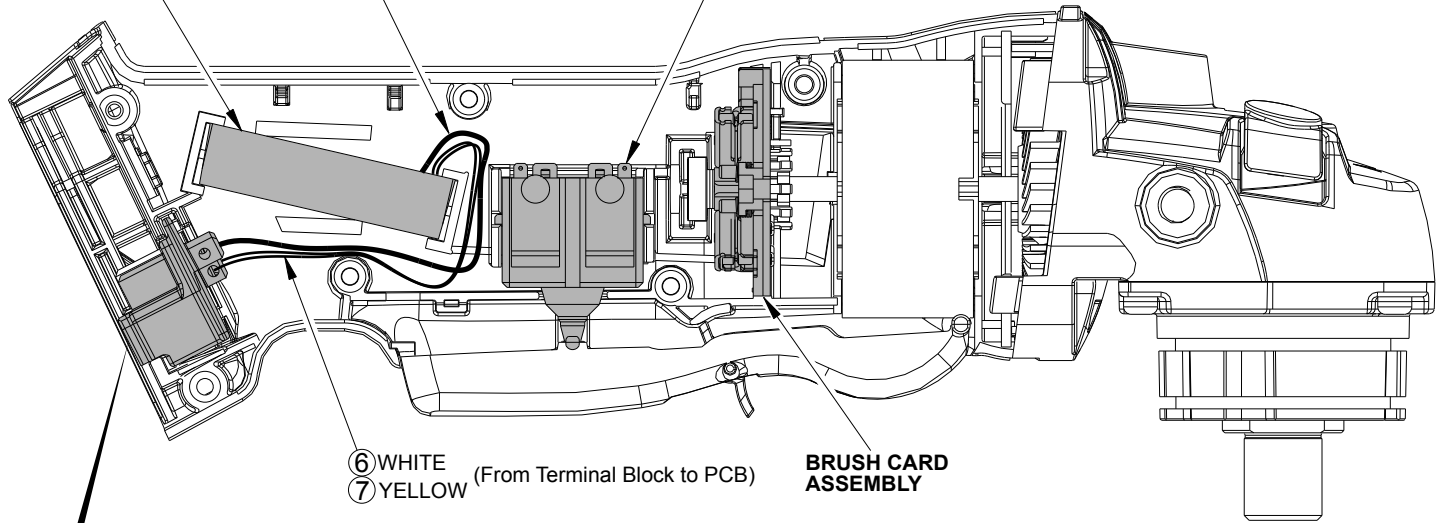

BLACK ②
(From Switch to PCB)

④ BLACK
(From Brush Card to Switch)

RED ③ (From Switch to PCB)

⑤ RED
(From Brush Card to Switch)

CONNECTOR BLOCK
(Component of the Electronics Module Assembly)

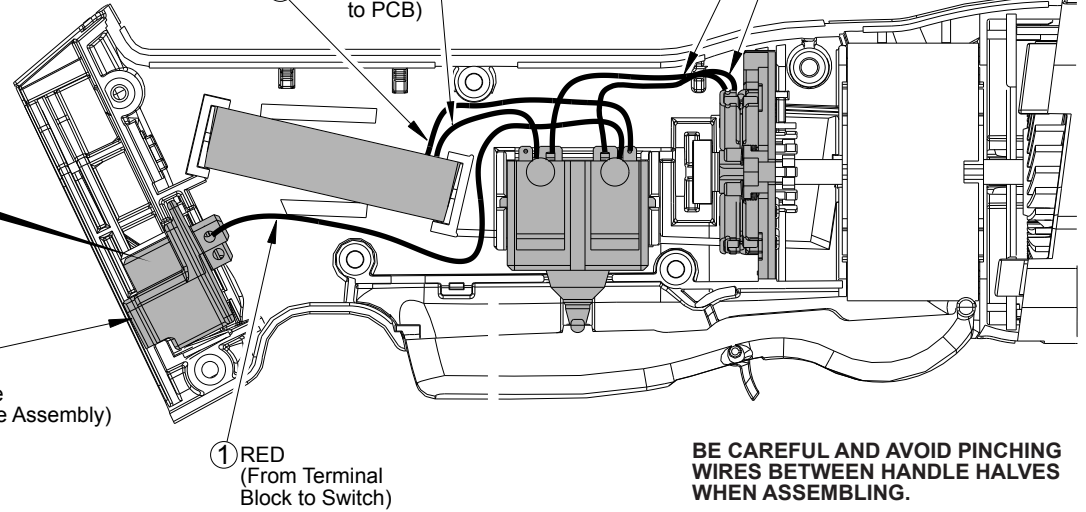

BE CAREFUL AND AVOID PINCHING WIRES BETWEEN HANDLE HALVES WHEN ASSEMBLING.

WIRING SPECIFICATIONS

Wire No.	Wire Color	Origin or Gauge	Length	Terminals, Connectors and 1 or 2 End Wire Preparation
1	Red	14	----	Component of the Electronics Module Assembly.
2	Black	14	----	Component of the Electronics Module Assembly.
3	Red	18	----	Component of the Electronics Module Assembly.
4	Black	15	----	Component of the Brush Card Assembly.
5	Red	15	----	Component of the Brush Card Assembly.
6	White	24	----	Component of the Electronics Module Assembly.
7	Yellow	24	----	Component of the Electronics Module Assembly.
8	Black	14	----	Component of the Electronics Module Assembly.

