

PART NUMBER	SIZE	"L"	"S"	"B"	"OD"	"BB"	"BE"
5142101	1½" x 1"	7 ½"	4"	2"	1.324"	1.894"	1.915"
5142102	2½" x 2"	6 ⅝"	2 ⅛"	3 ⅛"	2.375"	2.868"	2.890"
5142104	3" X 2"	7 ⅛"	2 ¼"	3"	2.375"	3.492"	3.515"
5142105	3" X 2½"	7 ½"	2 ⅞"	3 ⅛"	2.875"	3.492"	3.515"
5142106	2" X 1"	6 ⅝"	2 ⅞"	1 ¾"	1.315"	2.369"	2.393"
5142107	5" X 4"	11 ⅝"	4½"	3 ⅜"	4.500"	5.553"	5.593"
*5142108	4" X 2"	12"	2"	3.75"	2.375"	4.491"	4.540"
5142109	4" X 3"	7 ⅜"	2 ½"	3 ½"	3.500"	4.491"	4.515"
5142203	6" X 5"	9 ⅞"	3 ⅜"	3 ⅜"	5.563"	6.614"	6.658"
5142103	2" x 1½"	8 ⅛"	5 ¼"	1 ½"	1.900"	2.369"	2.393"
5142204	8" x 6"	OBSOLETE	OBSOLETE	OBSOLETE	OBSOLETE	OBSOLETE	OBSOLETE
5142257	2" x 1½"	5 ½"	2 ½"	1 ⅞"	1.900"	2.369"	2.393"
5142256	1½" x 1"	4 ¾"	1 ¼"	1 ⅞"	1.315"	1.894"	1.918"
*5142202	6" x 4"	17 ¾"	5"	3 ½"	4.500"	6.614"	6.640"

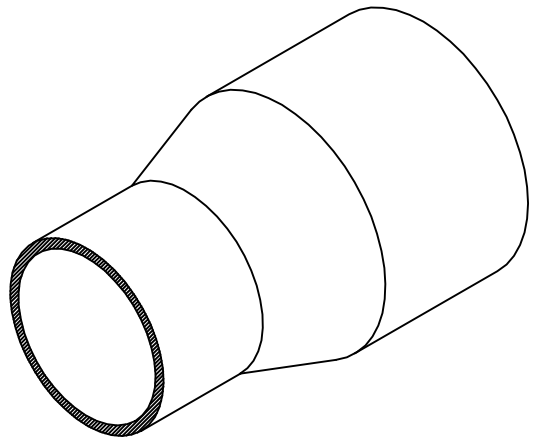
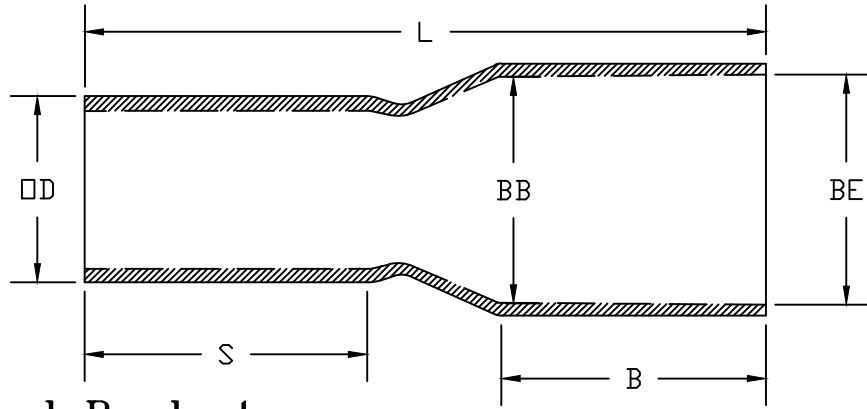

Not a Listed Product
 Linear dimensions are ± 1/4" UOS
 Conforms to NEMA TC 3
 *2-piece item

CANTEX INC. Fort Worth, TEXAS		
Bell to Spigot Fabricated Reducer Schedule 40		
Drawn By: O.M.	Date: 8/11/17	Ref. 5142101

PART NUMBER	SIZE	"L"	"S"	"B"	"OD"	"BB"	"BE"
5142101	1½" x 1"	7 ½"	4"	2"	1.324"	1.894"	1.915"
5142102	2½" x 2"	6 ⅝"	2 ⅛"	3 ⅛"	2.375"	2.868"	2.890"
5142104	3" X 2"	7 ⅛"	2 ¼"	3"	2.375"	3.492"	3.515"
5142105	3" X 2½"	7 ½"	2 ⅞"	3 ⅛"	2.875"	3.492"	3.515"
5142106	2" X 1"	6 ⅝"	2 ⅞"	1 ¾"	1.315"	2.369"	2.393"
5142107	5" X 4"	11 ⅝"	4½"	3 ⅜"	4.500"	5.553"	5.593"
*5142108	4" X 2"	12"	2"	3.75"	2.375"	4.491"	4.540"
5142109	4" X 3"	7 ⅜"	2 ½"	3 ½"	3.500"	4.491"	4.515"
5142203	6" X 5"	9 ⅞"	3 ⅜"	3 ⅜"	5.563"	6.614"	6.658"
5142103	2" x 1½"	8 ⅛"	5 ¼"	1 ½"	1.900"	2.369"	2.393"
5142204	8" x 6"	OBSOLETE	OBSOLETE	OBSOLETE	OBSOLETE	OBSOLETE	OBSOLETE
5142257	2" x 1½"	5 ½"	2 ½"	1 ⅞"	1.900"	2.369"	2.393"
5142256	1½" x 1"	4 ¾"	1 ¼"	1 ⅞"	1.315"	1.894"	1.918"
*5142202	6" x 4"	17 ¾"	5"	3 ½"	4.500"	6.614"	6.640"

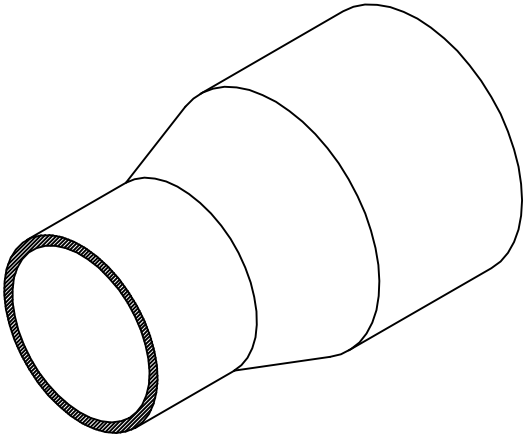
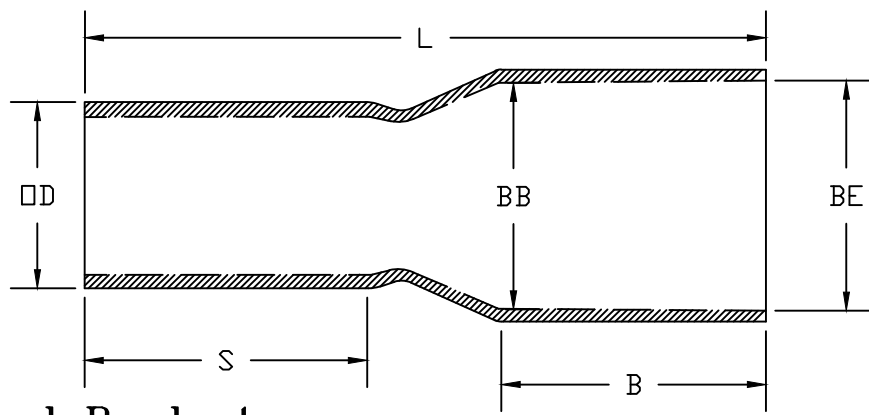

Not a Listed Product
 Linear dimensions are ± 1/4" UOS
 Conforms to NEMA TC 3
 *2-piece item

CANTEX INC. Fort Worth, TEXAS		
Bell to Spigot Fabricated Reducer Schedule 40		
Drawn By: O.M.	Date: 8/11/17	Ref. 5142101