

AG Series Surge Protective Devices

The AG Series Surge Protective Devices (SPD) are designed for a variety of Type 1 and Type 2 applications. Type 1 applications include outdoor installations before service entrances and utility meter cabinets. Type 2 applications include installations after service entrances. CSA listed to ANSI/UL1449 3rd edition, the AG series is approved for outdoor applications including: irrigation equipment, farm equipment, pumps, lighting fixtures, traffic signaling devices, HVACR controls, and motors.

Features

- UV resistant polycarbonate housing with 1/2" nominal nipple
- 18" leads; AG6503L3 – 36" leads
- Type 4 outdoor rainproof enclosure
- Green LED indicates surge protective status
- SPD Type 1 and/or Type 2 applications
- Limited 1-year warranty

Ratings

See Table Below

Project: _____

Location: _____

Product Type: _____

Contact/Phone: _____

Model #: _____



Model	Service Voltage	Poles	Wire Configurations	Nominal Discharge Current	Maximum Continuous Operation Voltage	1500L1/L3-L2 Voltage Protection Ratings (VPR)	
						L-N/G	L-L
AG24013/C3	120/240 VAC	1 or 2	L1, L2, N/G	20kA	150 L-N/G 300 L-L	700	1200
AG2083C3	208 VAC	3	L1, L2, L3, N/G	20kA	150 L-N/G 300 L-L	700	1200
AG48013	277/480 VAC	1 or 2	L1, L2, N/G	20kA	320 L-N/G 640 L-L	1200	2000
AG4803C3	277/480 VAC	3	L1, L2, L3, N/G	20kA	320 L-N/G 640 L-L	1200	2000
AG65033/C3/L3	347/600 VAC	3	L1, L2, L3, N/G	20kA	420 L-N/G 840 L-L	1500	2500
AG2403C3	120/208/240 (High Leg Delta)	3	L1, L2, L3, N/G	20kA	150 L1/L3-N/G 270 L2-N/G 300 L1-L3 420 L1/L3-L2	700 L1/L3-N/G 1000 L2-N/G	1200 L1-L3 1500 L1/L3-L2

Specification

The Surge Protective Device shall be listed by CSA to ANSI/UL 1449 3rd Edition for SPD Type 1 and Type 2 locations. The Surge Protective Device shall provide protection between each phase conductor and ground. The Maximum Continuous Operating Voltage (MCOV) shall be a minimum of ___VAC between phase and ground. When subjected to the ANSI/UL 1449 3rd Edition testing impulses, the Voltage Protection Rating shall be no greater than ___ Volts Line to Neutral/Ground or ___ Volts Line to Line. The Surge Protective device shall employ large MOV technology and provide individual component thermal protection and monitoring, utilizing a green LED status indicator light. The failure of a single component will turn the LED OFF. The rainproof housing shall be constructed of UV resistant polycarbonate, or material of equal strength and UV resistance, and tested to Type 4 standards for outdoor use. A ½ inch polycarbonate threaded nipple and metal locknut shall be provided. Leads shall be 12 gauge minimum and 24 inches in length. The Surge Protective Device shall carry a 1-year warranty and be manufactured by a company who has engaged in the manufacture of such products for a minimum of 5 years.

Diagrams

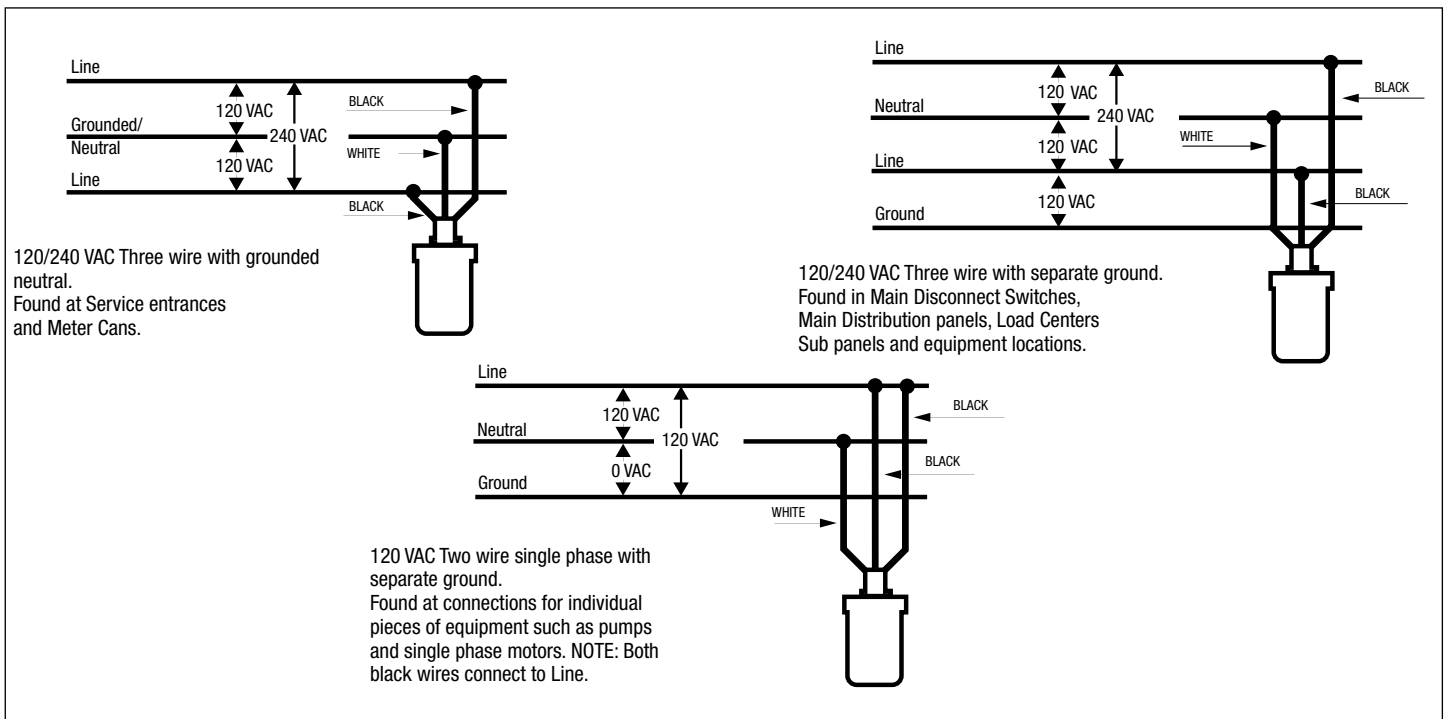

AG Series Surge Protective Devices

The AG Series Surge Protective Devices (SPD) are designed for a variety of Type 1 and Type 2 applications. Type 1 applications include outdoor installations before service entrances and utility meter cabinets. Type 2 applications include installations after service entrances. CSA listed to ANSI/UL1449 3rd edition, the AG series is approved for outdoor applications including: irrigation equipment, farm equipment, pumps, lighting fixtures, traffic signaling devices, HVACR controls, and motors.

Features

- UV resistant polycarbonate housing with ½" nominal nipple
- 18" leads; AG6503L3 – 36" leads
- Type 4 outdoor rainproof enclosure
- Green LED indicates surge protective status
- SPD Type 1 and/or Type 2 applications
- Limited 1-year warranty

Ratings

See Table Below

Project: _____

Location: _____

Product Type: _____

Contact/Phone: _____

Model #: _____



Model	Service Voltage	Poles	Wire Configurations	Nominal Discharge Current	Maximum Continuous Operation Voltage	1500L1/L3-L2 Voltage Protection Ratings (VPR)	
						L-N/G	L-L
AG24013/C3	120/240 VAC	1 or 2	L1, L2, N/G	20kA	150 L-N/G 300 L-L	700	1200
AG2083C3	208 VAC	3	L1, L2, L3, N/G	20kA	150 L-N/G 300 L-L	700	1200
AG48013	277/480 VAC	1 or 2	L1, L2, N/G	20kA	320 L-N/G 640 L-L	1200	2000
AG4803C3	277/480 VAC	3	L1, L2, L3, N/G	20kA	320 L-N/G 640 L-L	1200	2000
AG65033/C3/L3	347/600 VAC	3	L1, L2, L3, N/G	20kA	420 L-N/G 840 L-L	1500	2500
AG2403C3	120/208/240 (High Leg Delta)	3	L1, L2, L3, N/G	20kA	150 L1/L3-N/G 270 L2-N/G 300 L1-L3 420 L1/L3-L2	700 L1/L3-N/G 1000 L2-N/G	1200 L1-L3 1500 L1/L3-L2

Specification

The Surge Protective Device shall be listed by CSA to ANSI/UL 1449 3rd Edition for SPD Type 1 and Type 2 locations. The Surge Protective Device shall provide protection between each phase conductor and ground. The Maximum Continuous Operating Voltage (MCOV) shall be a minimum of ___VAC between phase and ground. When subjected to the ANSI/UL 1449 3rd Edition testing impulses, the Voltage Protection Rating shall be no greater than ___ Volts Line to Neutral/Ground or ___ Volts Line to Line. The Surge Protective device shall employ large MOV technology and provide individual component thermal protection and monitoring, utilizing a green LED status indicator light. The failure of a single component will turn the LED OFF. The rainproof housing shall be constructed of UV resistant polycarbonate, or material of equal strength and UV resistance, and tested to Type 4 standards for outdoor use. A ½ inch polycarbonate threaded nipple and metal locknut shall be provided. Leads shall be 12 gauge minimum and 24 inches in length. The Surge Protective Device shall carry a 1-year warranty and be manufactured by a company who has engaged in the manufacture of such products for a minimum of 5 years.

Diagrams

