

Carlton®

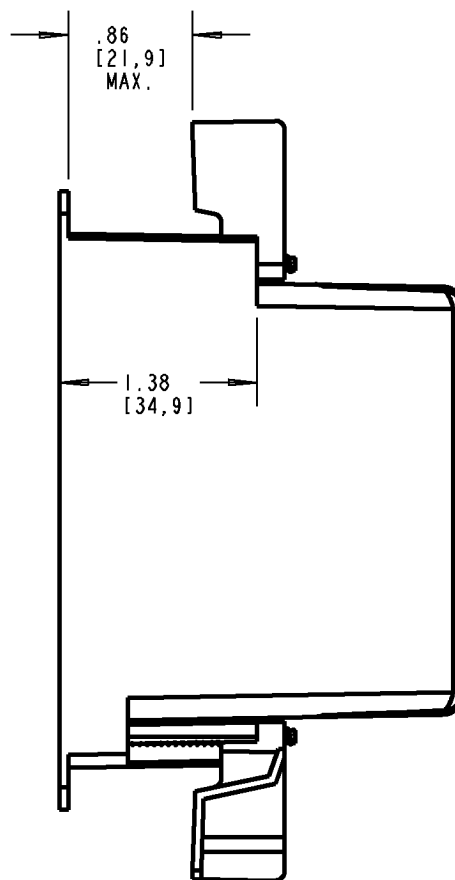
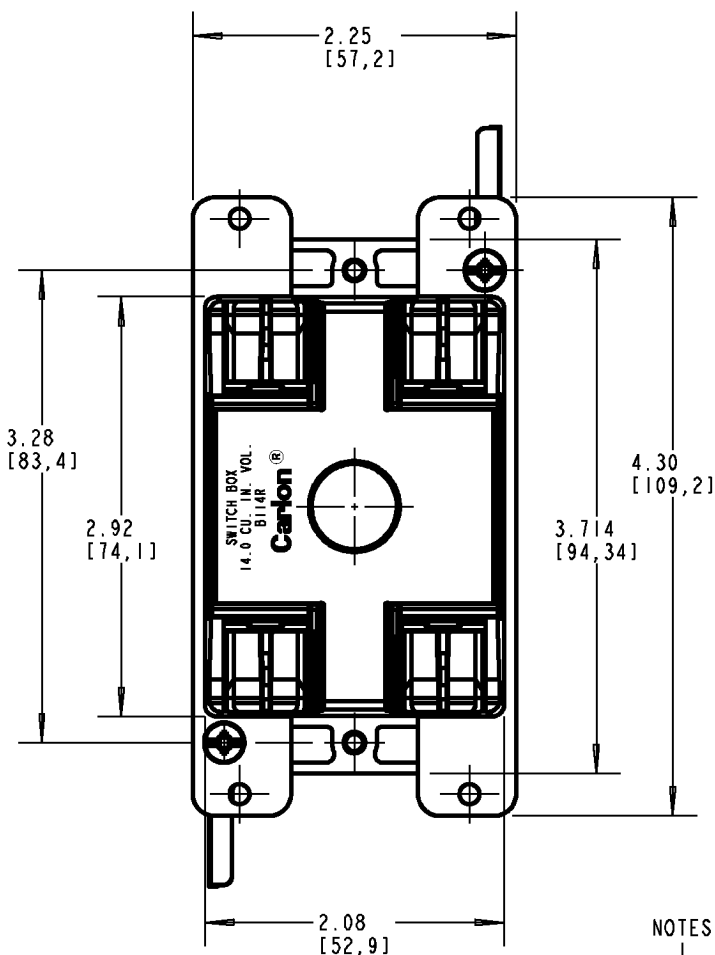
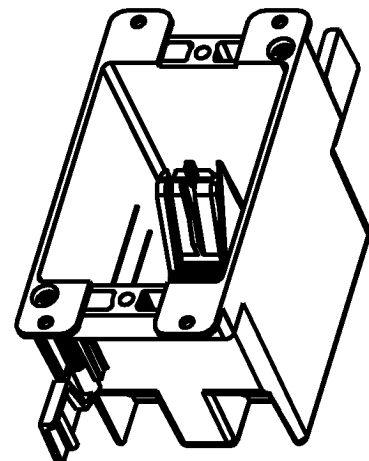
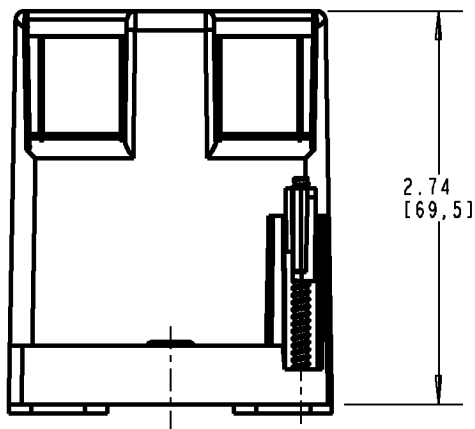

NOTES:
1. (2) #6-20X1-1/2" PAN HEAD SCREWS
& SWING CLAMPS INCLUDED.

P/N
B114RB
B114RR-UPC
B114R-UPC

GENERAL NOTES

1. ALL DIMENSIONS ARE FOR REFERENCE ONLY.
2. DIMENSIONS IN BRACKETS [] ARE IN METRIC UNITS.

REVISIONS

*** SEE ERN (****)
FOR APPROVAL SIGNATURES
& RELEASE DATE.
PROJECT NO: ****

Thomas & Betts
www.tnb.com

DESCRIPTION: **14 CU. IN. VOL. OLD WORK BOX**

ORIGINAL PROJECT NO / (ERN NO)

/ ()

SHEET NO:

1 OF 1

REV. NO:

C

DRAWING NO:

WSD-AC02067