

# Carlton®

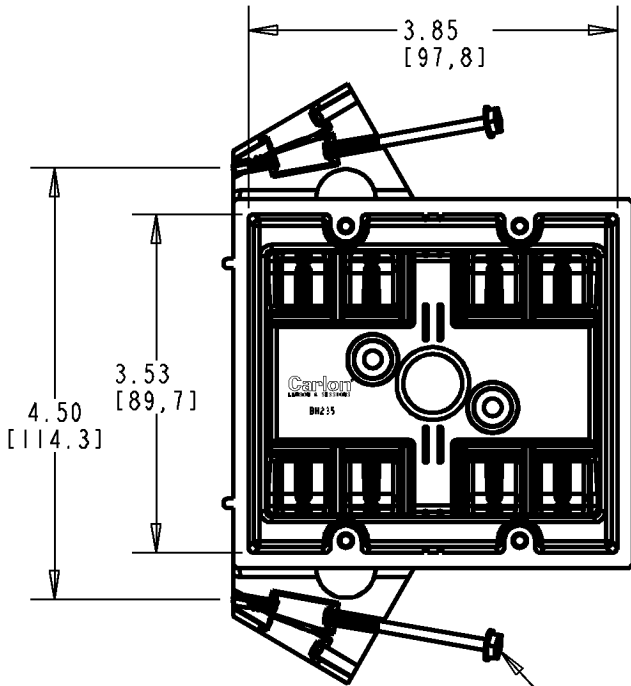

SCREWS P/N G311S

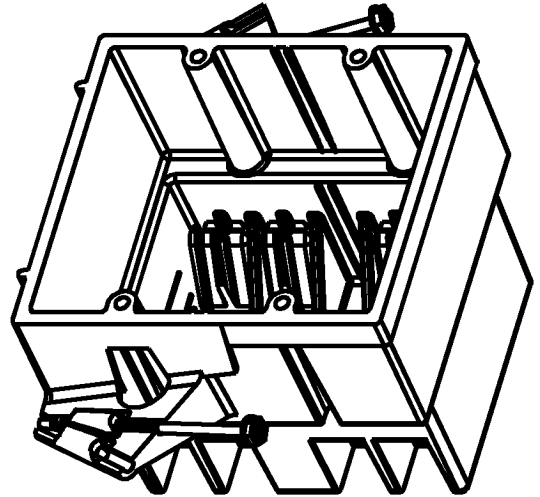
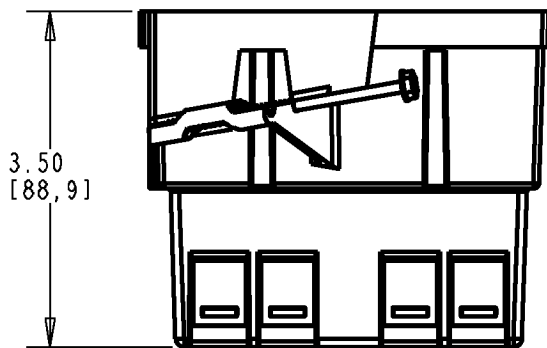

WIRE GA. / CONDUCTORS

17 / 14  
15 / 12  
14 / 10

P/N BH235S

**GENERAL NOTES**

1. ALL DIMENSIONS ARE FOR REFERENCE ONLY.
2. DIMENSIONS IN BRACKETS [ ] ARE IN METRIC UNITS.

**REVISIONS**

\*\*\* SEE ERN ( \*\*\*\* ) FOR APPROVAL SIGNATURES & RELEASE DATE.  
PROJECT NO: \*\*\*\*

**Thomas & Betts**  
www.tnb.com

DESCRIPTION: **2 GANG SUPER BLUE BLUE  
OUTLET & SWITCH BOX - 35 CU. IN. VOL.**

ORIGINAL PROJECT NO / ( ERN NO )  
/ ( )

SHEET NO:  
1 OF 2

REV. NO:  
A

DRAWING NO:  
**WSD-AC03643**

# Carlton®

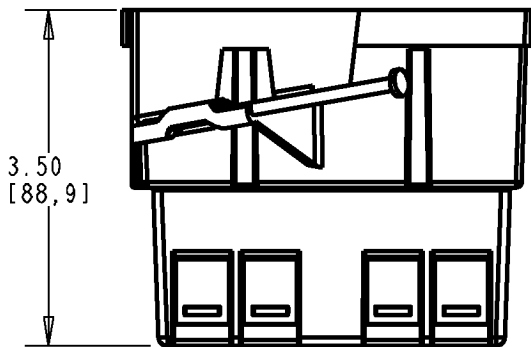
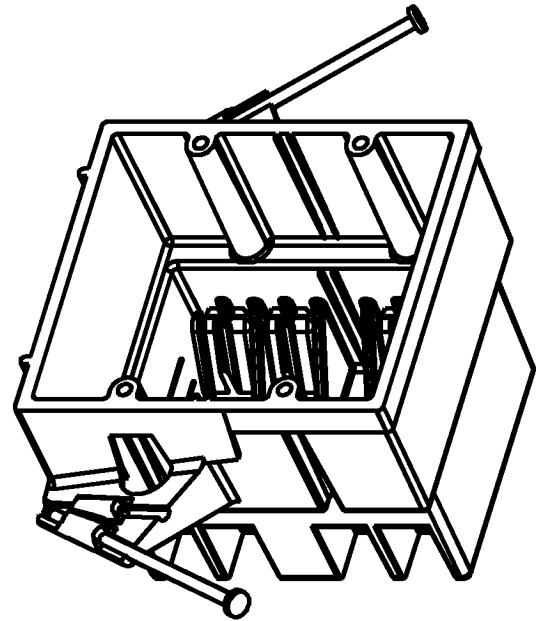
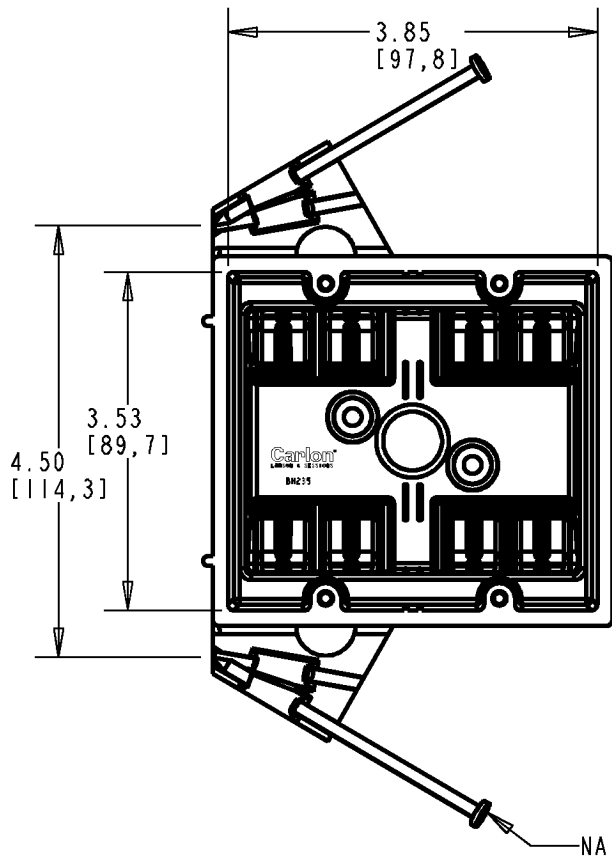

WIRE GA. / CONDUCTORS

17 / 14  
15 / 12  
14 / 10

P/N BH235A

**Thomas & Betts**  
www.tnb.com

DESCRIPTION: **2 GANG SUPER BLUE  
OUTLET & SWITCH BOX - 35 CU. IN. VOL.**

SHEET NO:  
**2 OF 2**

REV. NO:  
**A**

DRAWING NO:  
**AC03643**

# Carlton®

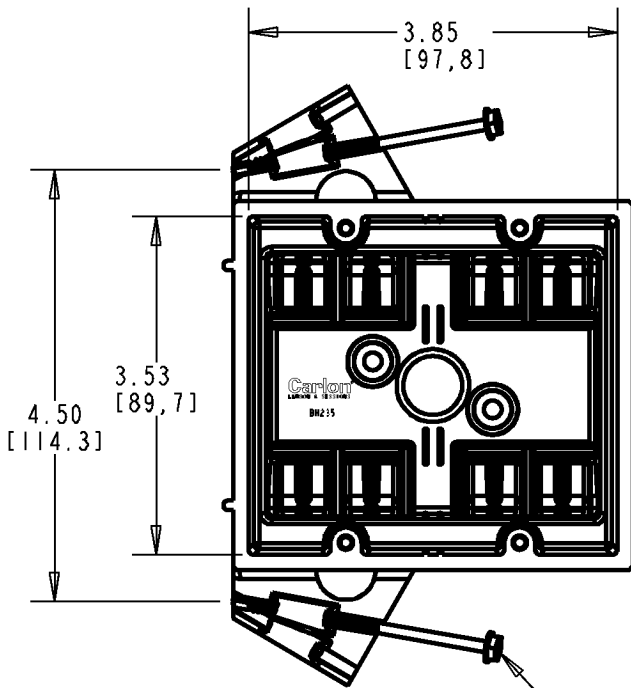
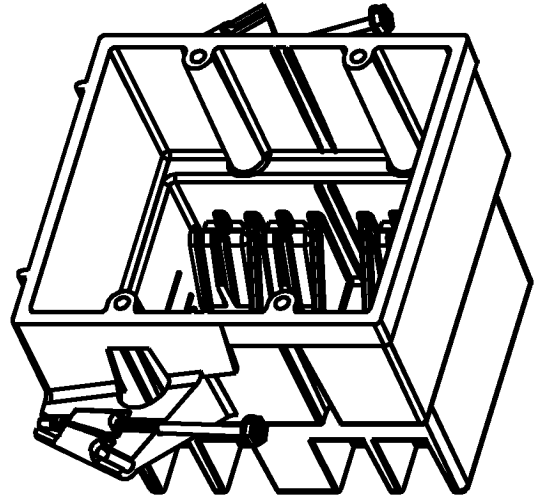

SCREWS P/N G311S

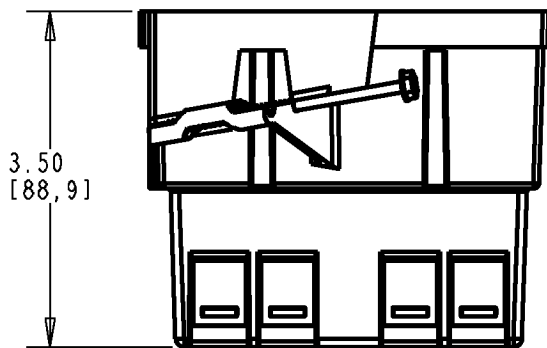

WIRE GA. / CONDUCTORS

17 / 14  
15 / 12  
14 / 10

P/N BH235S

**GENERAL NOTES**

1. ALL DIMENSIONS ARE FOR REFERENCE ONLY.
2. DIMENSIONS IN BRACKETS [ ] ARE IN METRIC UNITS.

**REVISIONS**

\*\*\* SEE ERN ( \*\*\*\* ) FOR APPROVAL SIGNATURES & RELEASE DATE.  
PROJECT NO: \*\*\*\*

**Thomas & Betts**  
www.tnb.com

DESCRIPTION: **2 GANG SUPER BLUE BLUE  
OUTLET & SWITCH BOX - 35 CU. IN. VOL.**

ORIGINAL PROJECT NO / ( ERN NO )	SHEET NO:	REV. NO:	DRAWING NO:
/ ( )	1 OF 2	A	<b>WSD-AC03643</b>

# Carlton®

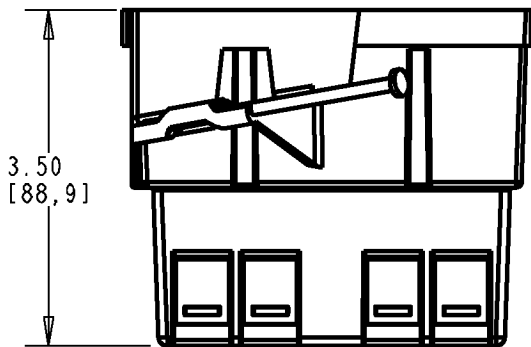
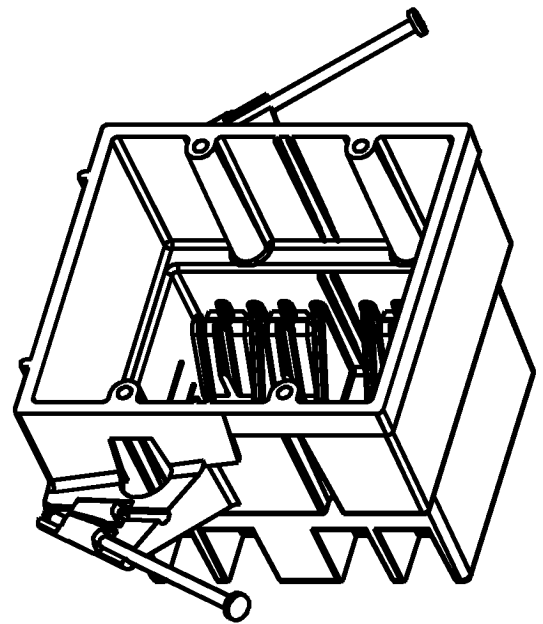
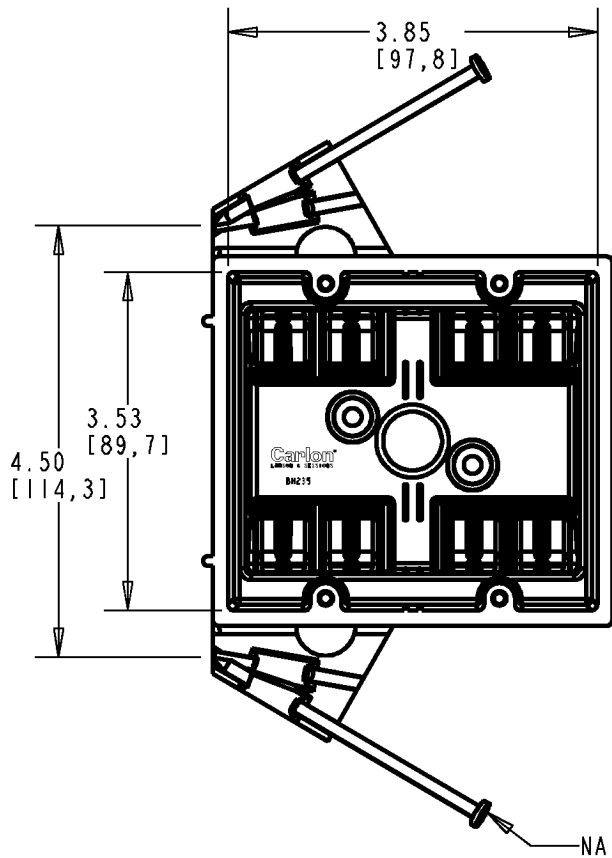

WIRE GA. / CONDUCTORS

17 / 14  
15 / 12  
14 / 10

P/N BH235A

**Thomas & Betts**  
www.tnb.com

DESCRIPTION: **2 GANG SUPER BLUE  
OUTLET & SWITCH BOX - 35 CU. IN. VOL.**

SHEET NO:  
**2 OF 2**

REV. NO:  
**A**

DRAWING NO:  
**AC03643**