

## NRC Series

NRC series circuit breakers offer circuit protection which is far superior to using fuses in applications containing relay circuits, motor circuits, heater circuits, transformers, solenoid valves, and semiconductors.

### Key features of the NRC series include:

- Mounting options include DIN rail, direct surface, or panel cut-out
- Rated interrupting capacity of 2,500A (1-pole) and 1,500A (2-pole)
- Choice of slide or lever actuators
- All models equipped with reset trip indicators
- Four curves available for standard or very short delay
- Available in 11 rated currents from 300mA to 30A
- UL1077 recognized "Supplementary Protectors"



UL Recognized  
File No. E68029



CSA Certified  
File No. LR83454

### Specifications

<b>Protection Method</b>	Electromagnetic tripping
<b>Internal Circuit</b>	Series current trip
<b>Number of Poles</b>	1, 2
<b>Rated Voltage</b>	250V AC (50/60Hz), 65V DC
<b>Rated Tripping Currents</b>	0.3A, 0.5A, 1A, 2A, 3A, 5A, 7A, 10A, 15A, 20A, 30A
<b>Rated Interrupting Capacity</b>	2,500A, 250V AC, 50/60Hz (2-pole: 1,500A)
<b>Auxiliary Contact</b>	SPDT contact output 250V AC 3A (resistive load) 65V DC 1A (resistive load)
<b>Reference Temperature</b>	40°C
<b>Operating Temperature</b>	-10 to +60°C (avoid freezing)
<b>Insulation Resistance</b>	100MΩ (500V megger)
<b>Dielectric Strength</b>	Between the live part and the ground, between terminals of different poles, between terminals of the same pole, and between main circuit and auxiliary contact: 2,000V AC, 1 minute
<b>Vibration Resistance</b>	100N (approximately 10G) (10 to 55Hz)
<b>Shock Resistance</b>	500N (approximately 50G)
<b>Life</b>	10,000 operations minimum
<b>Terminal Style</b>	Main terminal: M4 screw (20A maximum) M5 screw (30A model) Auxiliary terminal: M3.5 screw
<b>Weight (approximate)</b>	1-pole: 115g, 2-pole: 230g





Not suitable for branch circuit protection.

Part Numbering Guide

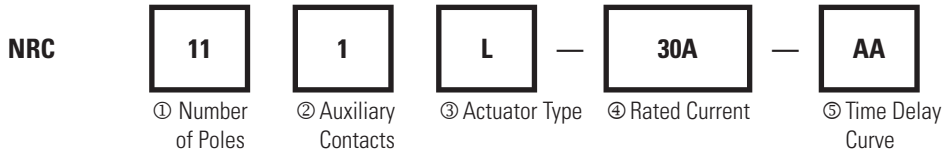
NRC series part numbers are composed of 5 part number codes. When ordering an NRC series part, select one code from each category.  
 Example: NRC 1 1 1L-30A-AA



Part Number Codes: NRA Series

	Appearance	Description	Part Number Code	Remarks
① No. of Poles		1-pole	11	
		2-pole	21	
② Auxiliary Contacts		No	0	
		Yes	1	
③ Actuator Type		Slide	Leave blank	Slide actuator available only for 1-pole models.
		Lever	L	
④ Rated Current			0.3A, 0.5A, 1A, 2A, 3A, 5A, 7A, 10A, 15A, 20A, 30A	
⑤ Time Delay Curve			AC curves: AA, EA; DC curves: AD, ED	

- 1. For NRC series accessories, see page 902.
- 2. For NRC series time delay curves, see page 903.
- 3. For NRC series dimensions, see page 905.

Switches & Pilot Lights

Display Lights

Relays & Sockets

Timers

Terminal Blocks

Circuit Breakers

Accessories

Part Numbers: DIN Rail and Mounting Clips

Description	Appearance	Part No.	Remarks
<b>Aluminum DIN Rail</b> (1 meter length)		BNDN1000	For dimensional drawing, see page 908.
<b>DIN Rail End Clip</b> Metal end clip used to prevent side-to-side movement of circuit breakers when mounted on a DIN rail. One clip required at each end.		BNL5	
<b>Panel Cut-Out Mounting Bracket</b> Mounting bracket used to mount circuit breaker(s) in panel cut-outs. Not applicable for models with auxiliary contacts (NRC111, NRC111L, NRC211L). When mounting 2-pole models (NRC210L), use two brackets side-by-side. It is recommended to use the "Fast-On Tab Terminal Adapter" (below) when using this bracket.		NRC-M	For dimensional drawings, see page 907.
<b>Surface Mounting Bracket</b> Used for direct surface mounting 1-pole circuit breaker models.		NRC-F	For dimensional drawings, see page 907.
<b>Fast-On Tab Terminal Adapter</b> Adapter used for Fast-On wiring termination. Fast-On tab extends 0.47" (12mm) in length. Cannot be used to replace models with M5 main terminals (30A). Fast-On terminal adapter recommended when using panel cut-out mounting bracket for rear wiring.		NRC-T	
<b>Jumper</b> Used for jumping auxiliary terminals. The rated current for jumper is 3A.		NRC-J	

For dimensions of NRC series accessories, see page 907.

Internal Circuits and Terminal Arrangements

Type	1-pole without auxiliary contact	1-pole with auxiliary contact	2-pole without auxiliary contact	2-pole with auxiliary contact
	NRC110, NRC110L	NRC111, NRC111L	NRC210L	NRC211L
Series Trip				

### Time Delay Curves (numerical equivalent)

#### Overcurrent — Time Delay Characteristics in Seconds (at 40°C)

		Percent of Rated Current								
		Curve	100%	125%	150%	200%	400%	600%	800%	1000%
AC (50/60Hz)	AA	No trip	40 – 240	10 – 50	3.5 – 18	0.9 – 4	0.35 – 2	0.07 – 1.2	0.01 – 0.5	
	EA	No trip	0.04 – 0.4	0.025 – 0.15	0.015 – 0.06	0.007 – 0.025	0.005 – 0.018	0.004 – 0.017	0.004 – 0.017	
DC	AD	No trip	40 – 240	10 – 50	3.5 – 18	0.6 – 3	0.008 – 0.5	0.005 – 0.09	0.004 – 0.07	
	ED	No trip	0.04 – 0.4	0.025 – 0.15	0.015 – 0.06	0.007 – 0.025	0.005 – 0.018	0.004 – 0.017	0.004 – 0.017	

1. All values above are in seconds.
2. Data in this table is equivalent to information presented in the time delay curves below.

#### Time Delay Curves

AC (50/60 Hz) Time Delay Curves

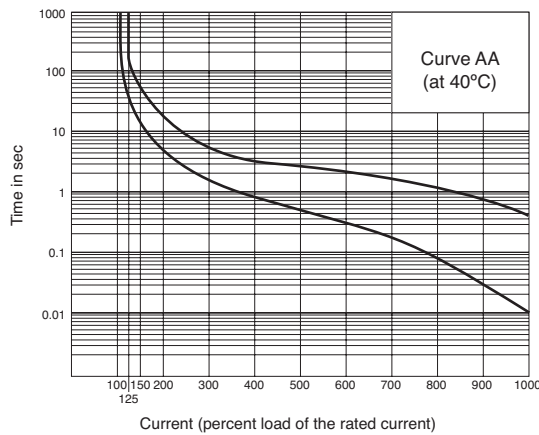

DC Time Delay Curves

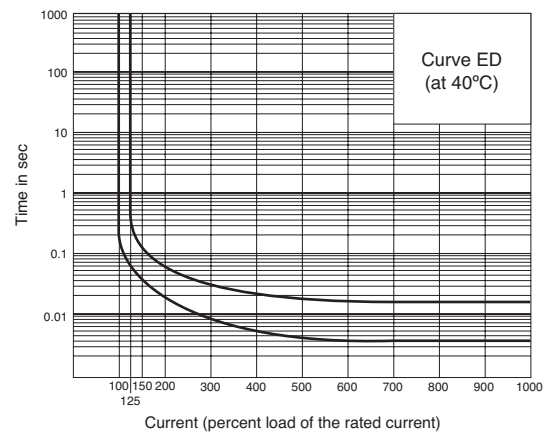
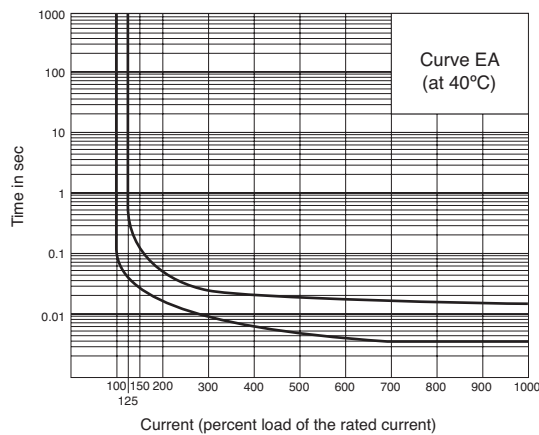
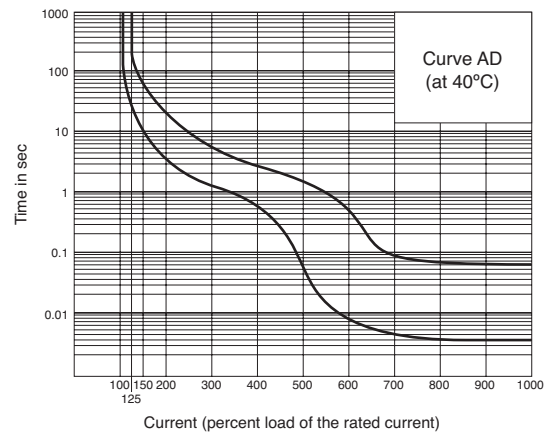

Switches & Pilot Lights

Display Lights

Relays & Sockets

Timers

Terminal Blocks

Circuit Breakers

**Resistance and Impedance Characteristics**

**Coil Impedance (at 40°C)**

Rated Current	AC Impedance (50/60Hz)	DC Resistance
0.30A	15.1Ω	25.6Ω
0.50A	5.58Ω	9.04Ω
1A	1.54Ω	2.33Ω
2A	0.341Ω	0.548Ω
3A	0.162Ω	0.261Ω
5A	0.061Ω	0.099Ω
7A	0.031Ω	0.048Ω
10A	0.017Ω	0.026Ω
15A	0.008Ω	0.013Ω
20A	0.0058Ω	0.0075Ω
30A	0.0039Ω	0.0046Ω

 Tolerance: ±10% (0.3A to 3A), ±25% (5A to 30A).

**AC Impedance at 40°C**

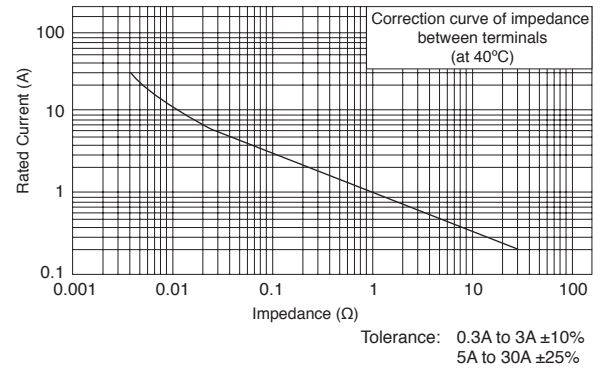

**DC Resistance at 40°C**

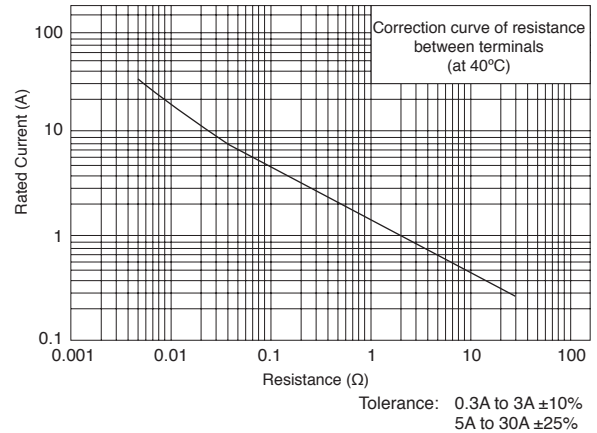

**Voltage Drop Due to Resistance or Impedance**

The internal impedance of a circuit breaker tends to be larger for a smaller rated current. Therefore, when low rated circuit breakers are used, voltage drop should be taken into consideration.

**Temperature Correction Curves**

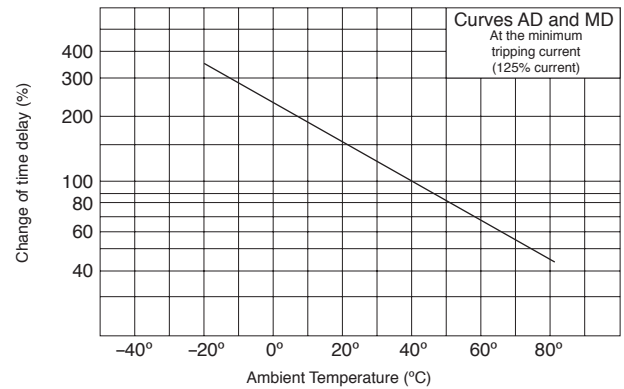

Switches & Pilot Lights

Display Lights

Relays & Sockets

Timers

Terminal Blocks

Circuit Breakers

Dimensions: NRC Series

**NRC110**

Slide Actuator  
1-Pole without Auxiliary Contacts

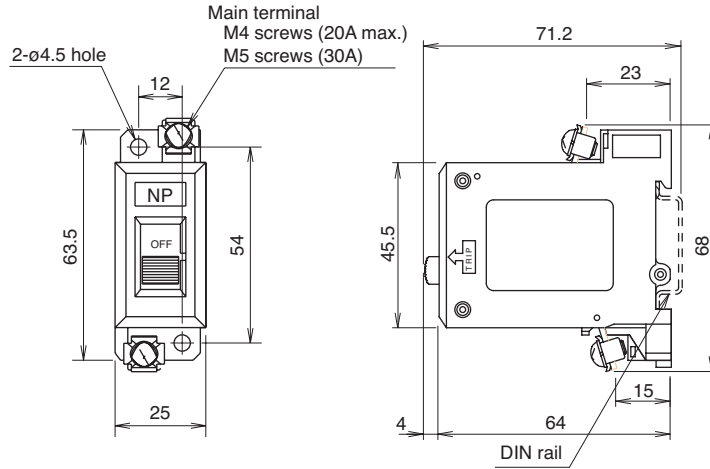

**NRC110L**

Lever Actuator  
1-Pole without Auxiliary Contacts

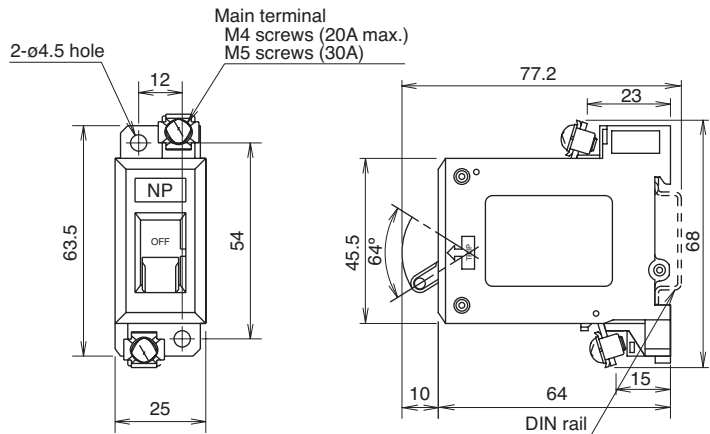

**NRC111**

Slide Actuator  
1-Pole with Auxiliary Contacts

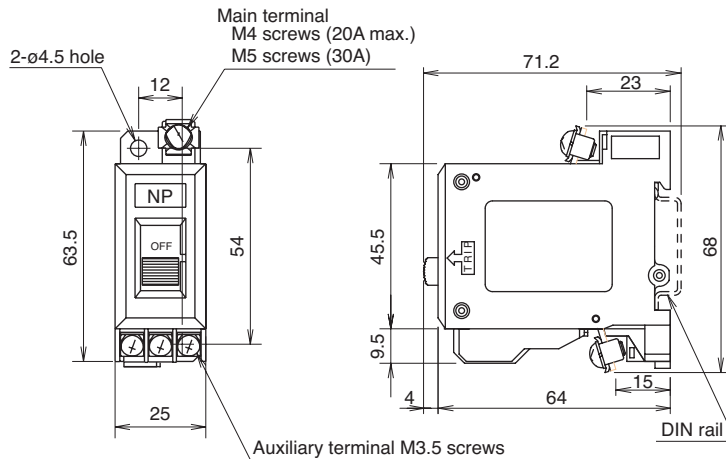

**Installation Angle:** Circuit breakers are designed to operate on a vertical surface. The mounting angle should not exceed a vertical plane by more than 10°.

**Dimensions: NRC Series, continued**

**NRC111L**

Lever Actuator  
1-Pole with Auxiliary Contacts

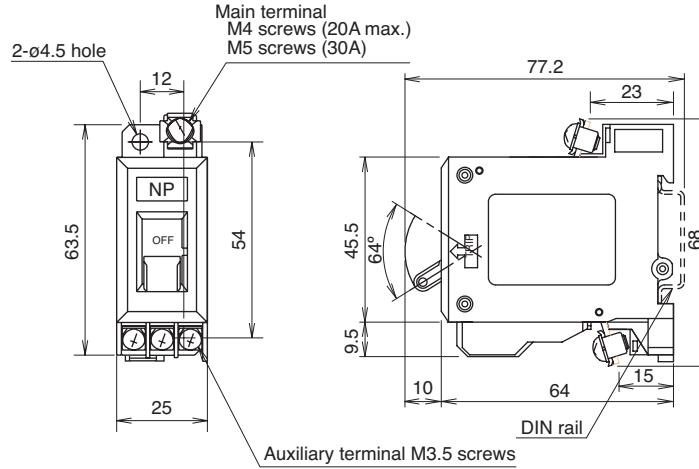

**NRC210L**

Lever Actuator  
2-Pole without Auxiliary Contacts

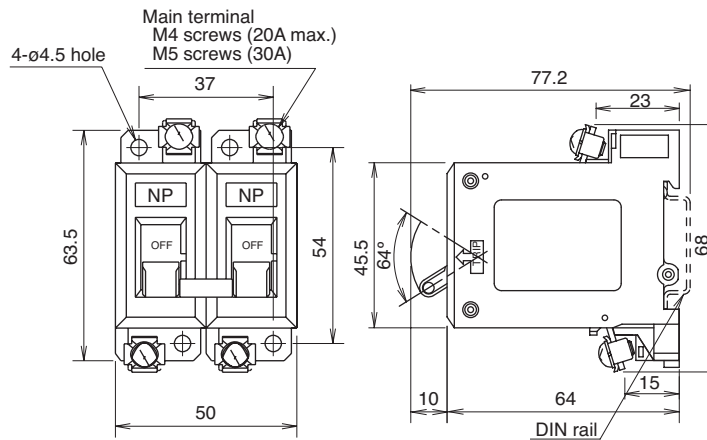

**NRC211L**

Lever Actuator  
2-Pole with Auxiliary Contacts

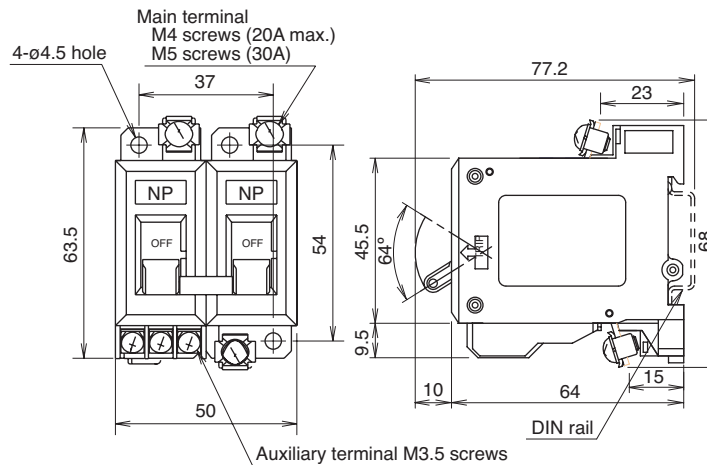

**Installation Angle:** Circuit breakers are designed to operate on a vertical surface. The mounting angle should not exceed a vertical plane by more than 10°.

Switches & Pilot Lights

Display Lights

Relays & Sockets

Timers

Terminal Blocks

Circuit Breakers

Panel Cut-Outs

NRC Series

Surface Mounting Hole Layout 1-Pole

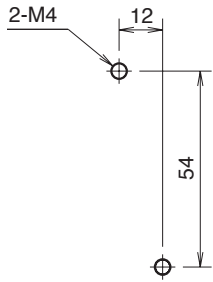

Surface Mounting Hole Layout 2-Pole

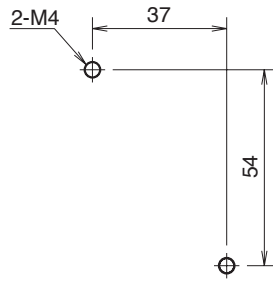

Panel Cut-Out (when using NRC-M)

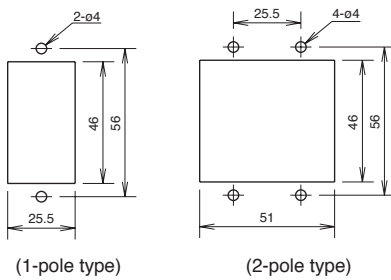

Accessory Dimensions

Panel Cut-Out Mounting Adapter (NRC-M)

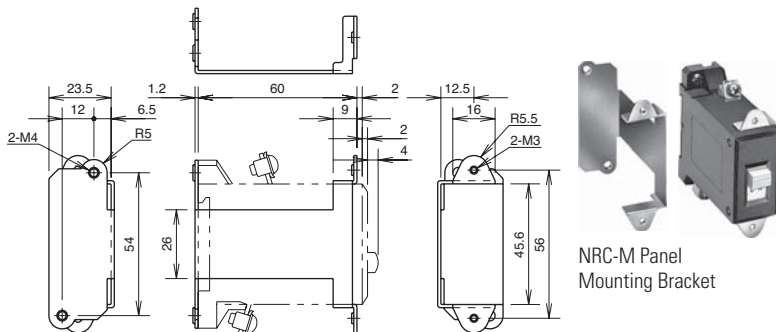

Surface Mounting Bracket (NRC-F)

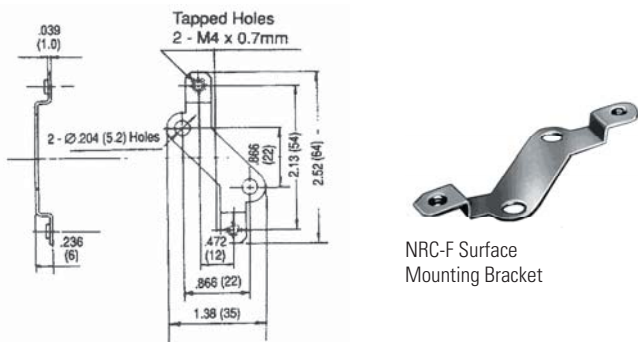



**Accessory Dimensions, continued**

**BNDN1000 Aluminum DIN Rail**

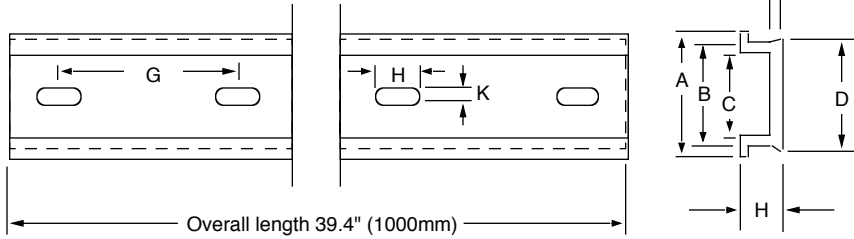

	Length in Inches (mm)
A	1.4" (35mm)
B	1.14" (29mm)
C	0.78" (23mm)
D	1.2" (31mm)
E	0.41" (10.5mm)
F	0.11" (3mm)
G	2" (51mm)
H	0.47" (12mm)
K	0.16" (4mm)

Switches & Pilot Lights

Display Lights

Relays & Sockets

Timers

Terminal Blocks

Circuit Breakers

Instructions: All Series

General

IDEC's circuit breakers have been developed for the protection of electrical circuits and small-sized electrical equipment and provide excellent protection against overloads and short-circuits.

Additionally, IDEC's circuit breakers are designed to suit specific needs. Each series offers unique circuit protection characteristics and a choice of actuator styles.

IDEC's Circuit Breaker Features

- Various models are available with different tripping characteristics and rated currents
- 1- to 3- multi-pole
- Inertia delay
- Auxiliary contacts and alarm contacts
- The electromagnetic tripping system is not affected by ambient temperature
- Safe trip-free mechanism
- Vibration- and impact-resistant design
- When using accessories such as plug-in bases, flush plates, and colored caps, a variety of mounting styles is possible — such as DIN rail mounting, snap mounting into panel cut-outs, and color-coded arrangement on the panel

Mounting Instructions: Installation Angle

Designed to be mounted on a vertical surface, the circuit breakers should be mounted on a surface within 10° of the vertical plane. If the circuit breaker is mounted on a horizontal surface or at any angle other than the specified angle, its characteristics will be changed.

Multi-Pole Assemble

Multi-pole types such as 2- or 3-pole should be assembled by IDEC. **Because of their characteristics, 1-pole breakers cannot be combined to produce multi-pole units.**

Internal Circuits Overview

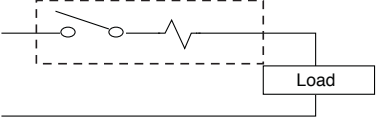
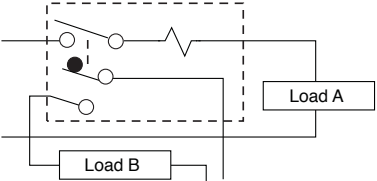
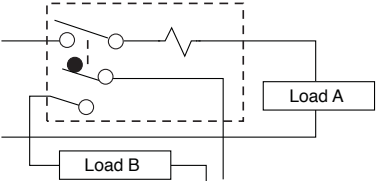
Description	Circuit Example
	<p><b>Series Trip</b> This is the most common circuit breaker, providing overload and short circuit protection. It can also be used as an ON/OFF switch.</p>
	<p><b>Series Trip with Auxiliary Contact</b> Since the auxiliary contact operation is interlocked with the ON/OFF of the main contactor, circuit breaker operation can be monitored by a lamp or buzzer. This circuit breaker can also be used to control auxiliary circuits up to 250V AC/5A (resistive load).</p>
	<p><b>Series Trip with Alarm Contact</b> Since the alarm contact is electrically independent of the main contactor, but actuates when the protective element operates. The alarm can be used with a lamp or buzzer to monitor trip operations, and can also be used for controlling alarm circuits. The contact rating is 250V AC/5A (resistive load).</p>

Applications

The IDEC NRA circuit breaker series features superior overload and short-circuit protection. Many combinations of protection mechanisms and internal circuit connections enable wide applications.

- **Precision measuring instruments:** electronic counters, projection instruments, oscilloscopes, industrial instrumentation, and analytic devices
- **Industrial machinery:** printers, elevators, cranes
- **Chemical and food industry machines:** vacuum devices, wrappers, centrifuges, agitators
- **Machine tools:** mill grinders, drills, presses
- **Business machines:** vending machines, beauty salon equipment, entertainment games
- **Other:** office equipment, air-conditioners, conveyor belts, and many more

How the Breaker Operates

IDEC's hydraulic magnetic circuit breakers operate like a solenoid coil. The coil unit consists of an oil-filled tube with a metal core at one end and a pole piece and armature at the opposite end with a spring in between.

When a current load passes through the coil winding, it creates a magnetic field. As long as the current load is either at or below the nominal rating of the breaker, the metal core will remain stationary.

If the current load increases beyond the nominal rating, the strength of the magnetic field causes the core to move toward the pole-end of the tube. The oil viscosity regulates the core's movement through the tube, thereby regulating the time delay. As the percentage of current load increases, the required trip time of the breaker decreases and vice versa.

When the current reaches the overload rating, the metal core will meet the pole piece at the opposite end of the tube. At this point, the armature is attracted to the same pole piece, tripping the breaker.

In case of sudden short circuit, the magnetic field created will instantly trip the breaker.

## NRC Series

NRC series circuit breakers offer circuit protection which is far superior to using fuses in applications containing relay circuits, motor circuits, heater circuits, transformers, solenoid valves, and semiconductors.

### Key features of the NRC series include:

- Mounting options include DIN rail, direct surface, or panel cut-out
- Rated interrupting capacity of 2,500A (1-pole) and 1,500A (2-pole)
- Choice of slide or lever actuators
- All models equipped with reset trip indicators
- Four curves available for standard or very short delay
- Available in 11 rated currents from 300mA to 30A
- UL1077 recognized "Supplementary Protectors"



UL Recognized  
File No. E68029



CSA Certified  
File No. LR83454

### Specifications

<b>Protection Method</b>	Electromagnetic tripping
<b>Internal Circuit</b>	Series current trip
<b>Number of Poles</b>	1, 2
<b>Rated Voltage</b>	250V AC (50/60Hz), 65V DC
<b>Rated Tripping Currents</b>	0.3A, 0.5A, 1A, 2A, 3A, 5A, 7A, 10A, 15A, 20A, 30A
<b>Rated Interrupting Capacity</b>	2,500A, 250V AC, 50/60Hz (2-pole: 1,500A)
<b>Auxiliary Contact</b>	SPDT contact output 250V AC 3A (resistive load) 65V DC 1A (resistive load)
<b>Reference Temperature</b>	40°C
<b>Operating Temperature</b>	-10 to +60°C (avoid freezing)
<b>Insulation Resistance</b>	100MΩ (500V megger)
<b>Dielectric Strength</b>	Between the live part and the ground, between terminals of different poles, between terminals of the same pole, and between main circuit and auxiliary contact: 2,000V AC, 1 minute
<b>Vibration Resistance</b>	100N (approximately 10G) (10 to 55Hz)
<b>Shock Resistance</b>	500N (approximately 50G)
<b>Life</b>	10,000 operations minimum
<b>Terminal Style</b>	Main terminal: M4 screw (20A maximum) M5 screw (30A model) Auxiliary terminal: M3.5 screw
<b>Weight (approximate)</b>	1-pole: 115g, 2-pole: 230g





Not suitable for branch circuit protection.

### Part Numbering Guide

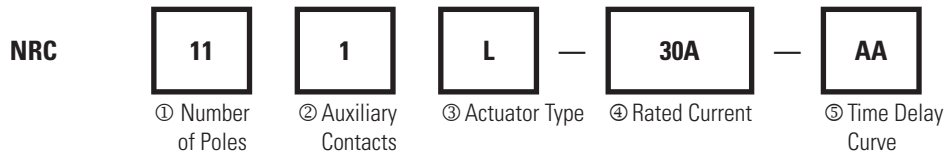
NRC series part numbers are composed of 5 part number codes. When ordering an NRC series part, select one code from each category.  
 Example: NRC 1 1 1L-30A-AA



#### Part Number Codes: NRA Series

	Appearance	Description	Part Number Code	Remarks
① No. of Poles		1-pole	11	
		2-pole	21	
② Auxiliary Contacts		No	0	
		Yes	1	
③ Actuator Type		Slide	Leave blank	Slide actuator available only for 1-pole models.
		Lever	L	
④ Rated Current			0.3A, 0.5A, 1A, 2A, 3A, 5A, 7A, 10A, 15A, 20A, 30A	
⑤ Time Delay Curve			AC curves: AA, EA; DC curves: AD, ED	

- 1. For NRC series accessories, see page 902.
- 2. For NRC series time delay curves, see page 903.
- 3. For NRC series dimensions, see page 905.

Switches & Pilot Lights

Display Lights

Relays & Sockets

Timers

Terminal Blocks

Circuit Breakers

Accessories

Part Numbers: DIN Rail and Mounting Clips

Description	Appearance	Part No.	Remarks
<b>Aluminum DIN Rail</b> (1 meter length)		BNDN1000	For dimensional drawing, see page 908.
<b>DIN Rail End Clip</b> Metal end clip used to prevent side-to-side movement of circuit breakers when mounted on a DIN rail. One clip required at each end.		BNL5	
<b>Panel Cut-Out Mounting Bracket</b> Mounting bracket used to mount circuit breaker(s) in panel cut-outs. Not applicable for models with auxiliary contacts (NRC111, NRC111L, NRC211L). When mounting 2-pole models (NRC210L), use two brackets side-by-side. It is recommended to use the "Fast-On Tab Terminal Adapter" (below) when using this bracket.		NRC-M	For dimensional drawings, see page 907.
<b>Surface Mounting Bracket</b> Used for direct surface mounting 1-pole circuit breaker models.		NRC-F	For dimensional drawings, see page 907.
<b>Fast-On Tab Terminal Adapter</b> Adapter used for Fast-On wiring termination. Fast-On tab extends 0.47" (12mm) in length. Cannot be used to replace models with M5 main terminals (30A). Fast-On terminal adapter recommended when using panel cut-out mounting bracket for rear wiring.		NRC-T	
<b>Jumper</b> Used for jumping auxiliary terminals. The rated current for jumper is 3A.		NRC-J	

For dimensions of NRC series accessories, see page 907.

Internal Circuits and Terminal Arrangements

Type	1-pole without auxiliary contact	1-pole with auxiliary contact	2-pole without auxiliary contact	2-pole with auxiliary contact
	NRC110, NRC110L	NRC111, NRC111L	NRC210L	NRC211L
Series Trip				

### Time Delay Curves (numerical equivalent)

#### Overcurrent — Time Delay Characteristics in Seconds (at 40°C)

		Percent of Rated Current								
		Curve	100%	125%	150%	200%	400%	600%	800%	1000%
AC (50/60Hz)	AA	No trip	40 – 240	10 – 50	3.5 – 18	0.9 – 4	0.35 – 2	0.07 – 1.2	0.01 – 0.5	
	EA	No trip	0.04 – 0.4	0.025 – 0.15	0.015 – 0.06	0.007 – 0.025	0.005 – 0.018	0.004 – 0.017	0.004 – 0.017	
DC	AD	No trip	40 – 240	10 – 50	3.5 – 18	0.6 – 3	0.008 – 0.5	0.005 – 0.09	0.004 – 0.07	
	ED	No trip	0.04 – 0.4	0.025 – 0.15	0.015 – 0.06	0.007 – 0.025	0.005 – 0.018	0.004 – 0.017	0.004 – 0.017	

1. All values above are in seconds.
2. Data in this table is equivalent to information presented in the time delay curves below.

#### Time Delay Curves

AC (50/60 Hz) Time Delay Curves

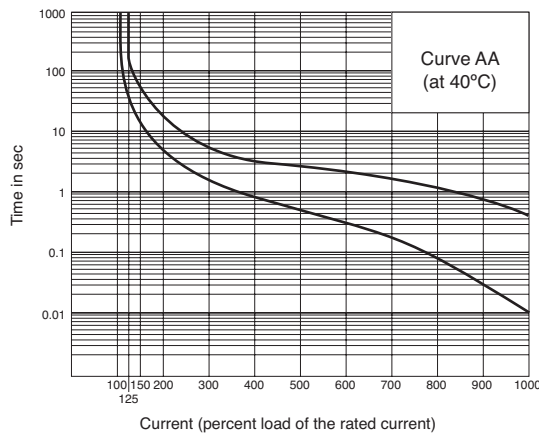

DC Time Delay Curves

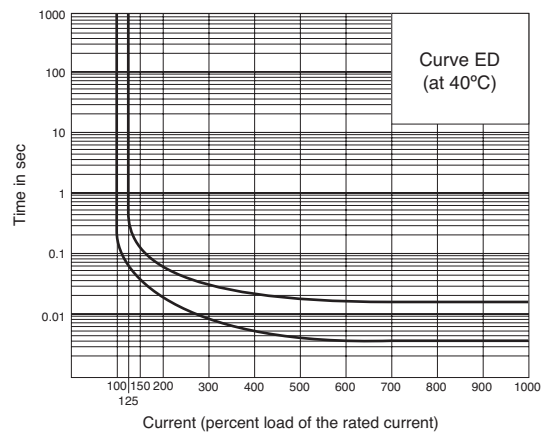
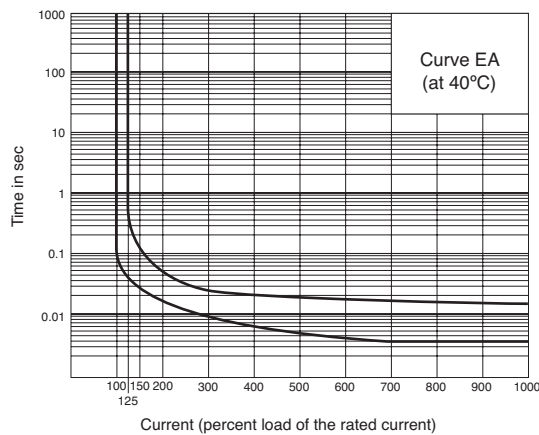
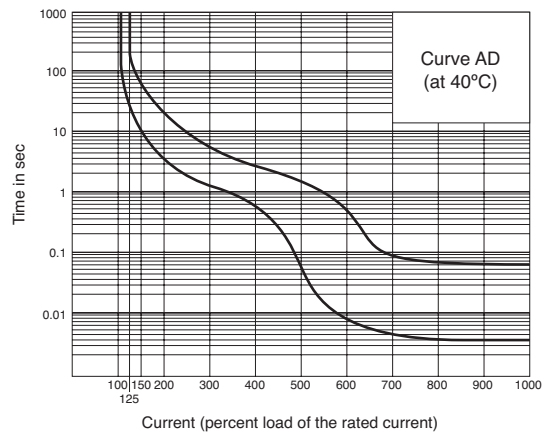

Switches & Pilot Lights

Display Lights

Relays & Sockets

Timers

Terminal Blocks

Circuit Breakers

**Resistance and Impedance Characteristics**

**Coil Impedance (at 40°C)**

Rated Current	AC Impedance (50/60Hz)	DC Resistance
0.30A	15.1Ω	25.6Ω
0.50A	5.58Ω	9.04Ω
1A	1.54Ω	2.33Ω
2A	0.341Ω	0.548Ω
3A	0.162Ω	0.261Ω
5A	0.061Ω	0.099Ω
7A	0.031Ω	0.048Ω
10A	0.017Ω	0.026Ω
15A	0.008Ω	0.013Ω
20A	0.0058Ω	0.0075Ω
30A	0.0039Ω	0.0046Ω

 Tolerance: ±10% (0.3A to 3A), ±25% (5A to 30A).

**AC Impedance at 40°C**

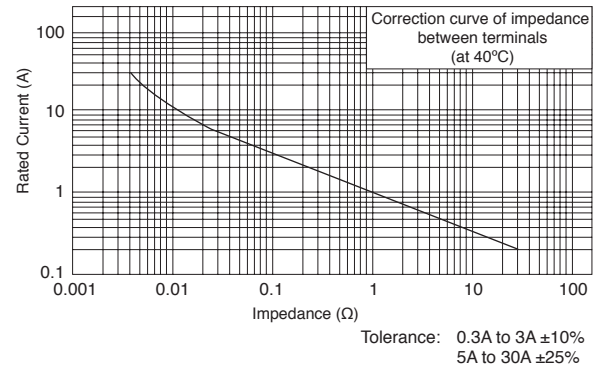

**DC Resistance at 40°C**

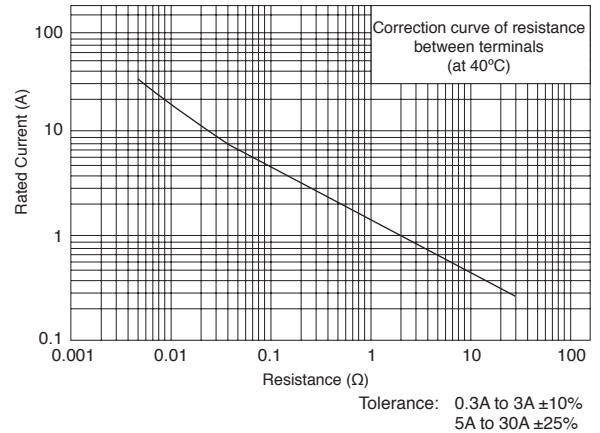

**Voltage Drop Due to Resistance or Impedance**

The internal impedance of a circuit breaker tends to be larger for a smaller rated current. Therefore, when low rated circuit breakers are used, voltage drop should be taken into consideration.

**Temperature Correction Curves**

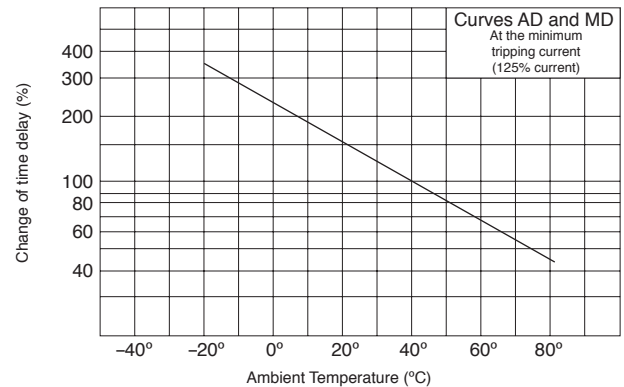

Dimensions: NRC Series

**NRC110**

Slide Actuator  
1-Pole without Auxiliary Contacts

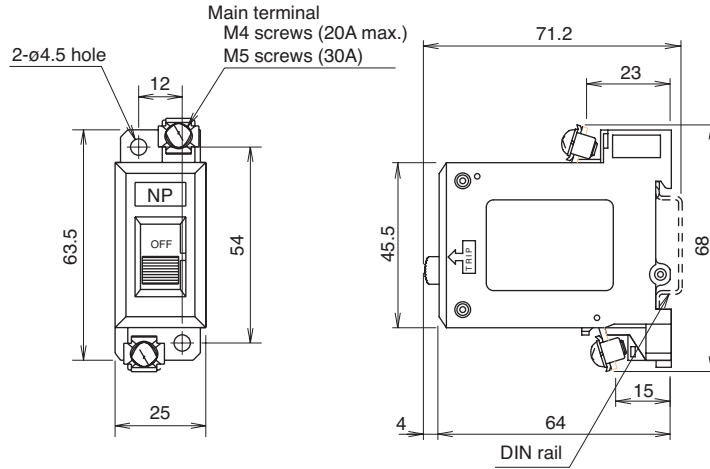

**NRC110L**

Lever Actuator  
1-Pole without Auxiliary Contacts

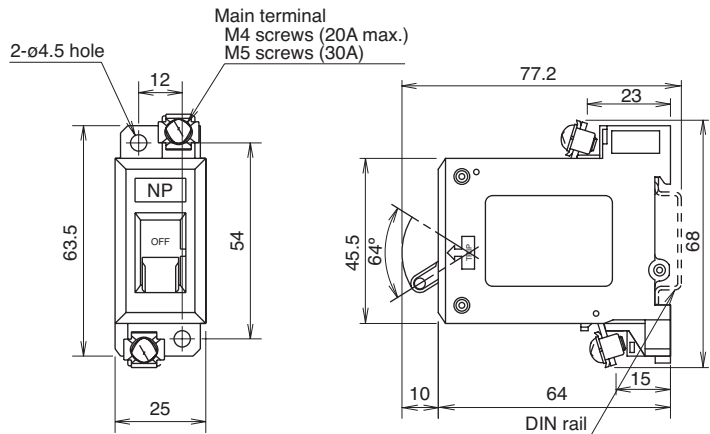

**NRC111**

Slide Actuator  
1-Pole with Auxiliary Contacts

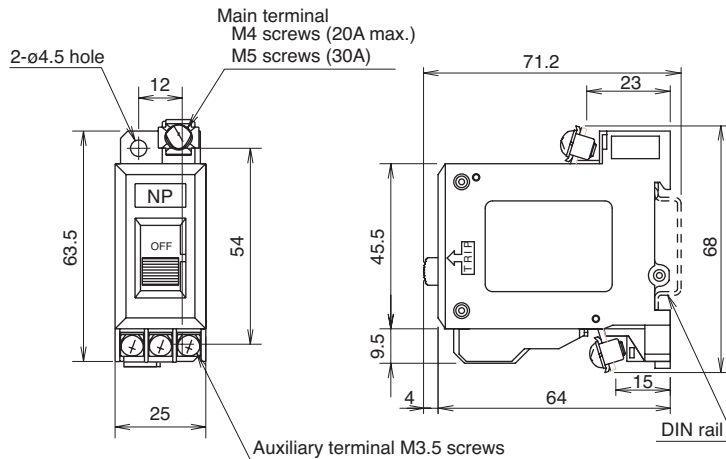

Switches & Pilot Lights

Display Lights

Relays & Sockets

Timers

Terminal Blocks

Circuit Breakers



**Installation Angle:** Circuit breakers are designed to operate on a vertical surface. The mounting angle should not exceed a vertical plane by more than 10°.



**Dimensions: NRC Series, continued**

**NRC111L**

Lever Actuator  
1-Pole with Auxiliary Contacts

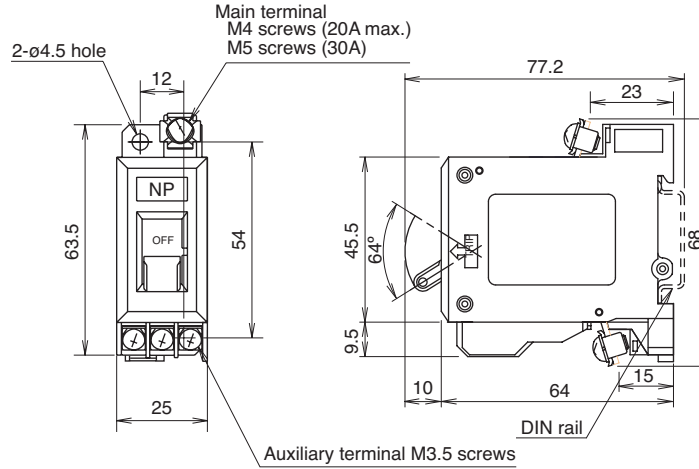

**NRC210L**

Lever Actuator  
2-Pole without Auxiliary Contacts

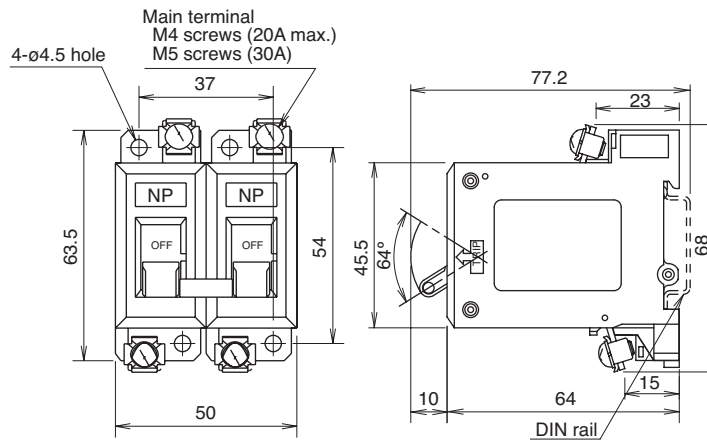

**NRC211L**

Lever Actuator  
2-Pole with Auxiliary Contacts

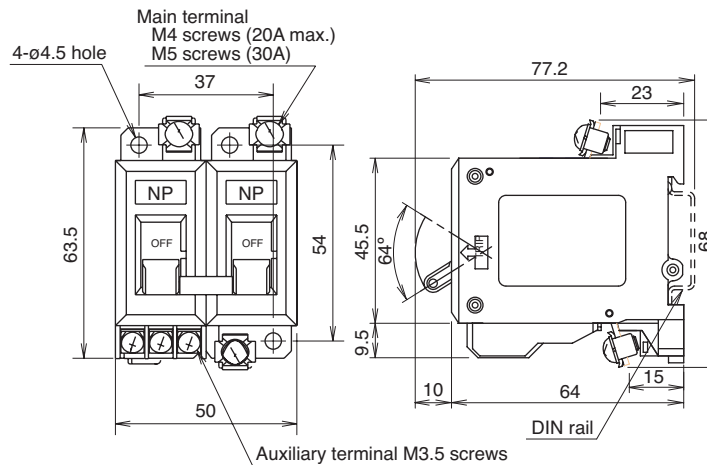

**Installation Angle:** Circuit breakers are designed to operate on a vertical surface. The mounting angle should not exceed a vertical plane by more than 10°.

Switches & Pilot Lights

Display Lights

Relays & Sockets

Timers

Terminal Blocks

Circuit Breakers

Panel Cut-Outs

NRC Series

Surface Mounting Hole Layout 1-Pole

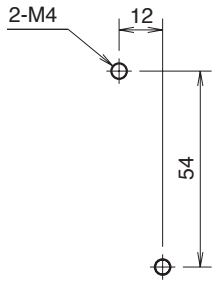

Surface Mounting Hole Layout 2-Pole

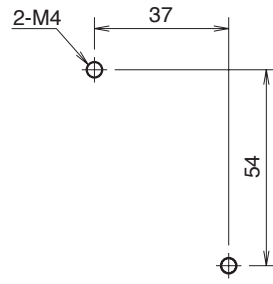

Panel Cut-Out (when using NRC-M)

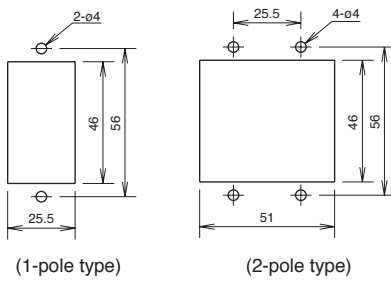

Accessory Dimensions

Panel Cut-Out Mounting Adapter (NRC-M)

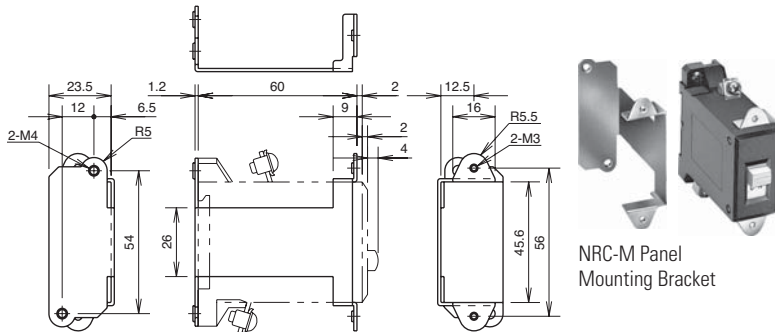

Surface Mounting Bracket (NRC-F)

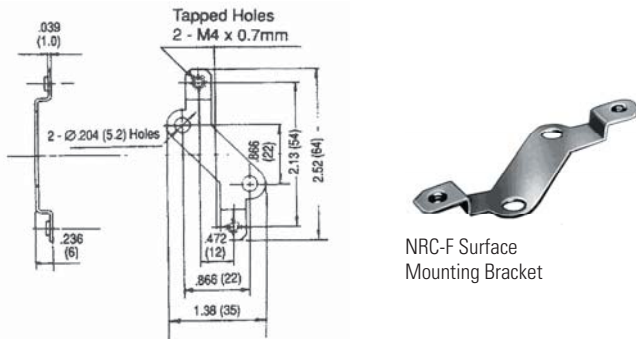

**Accessory Dimensions, continued**

**BNDN1000 Aluminum DIN Rail**

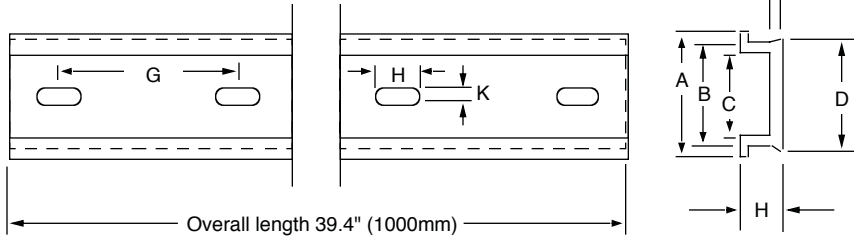

	Length in Inches (mm)
A	1.4" (35mm)
B	1.14" (29mm)
C	0.78" (23mm)
D	1.2" (31mm)
E	0.41" (10.5mm)
F	0.11" (3mm)
G	2" (51mm)
H	0.47" (12mm)
K	0.16" (4mm)

Switches & Pilot Lights

Display Lights

Relays & Sockets

Timers

Terminal Blocks

Circuit Breakers

Instructions: All Series

General

IDEC's circuit breakers have been developed for the protection of electrical circuits and small-sized electrical equipment and provide excellent protection against overloads and short-circuits.

Additionally, IDEC's circuit breakers are designed to suit specific needs. Each series offers unique circuit protection characteristics and a choice of actuator styles.

IDEC's Circuit Breaker Features

- Various models are available with different tripping characteristics and rated currents
- 1- to 3- multi-pole
- Inertia delay
- Auxiliary contacts and alarm contacts
- The electromagnetic tripping system is not affected by ambient temperature
- Safe trip-free mechanism
- Vibration- and impact-resistant design
- When using accessories such as plug-in bases, flush plates, and colored caps, a variety of mounting styles is possible — such as DIN rail mounting, snap mounting into panel cut-outs, and color-coded arrangement on the panel

Mounting Instructions: Installation Angle

Designed to be mounted on a vertical surface, the circuit breakers should be mounted on a surface within 10° of the vertical plane. If the circuit breaker is mounted on a horizontal surface or at any angle other than the specified angle, its characteristics will be changed.

Multi-Pole Assemble

Multi-pole types such as 2- or 3-pole should be assembled by IDEC. **Because of their characteristics, 1-pole breakers cannot be combined to produce multi-pole units.**

Internal Circuits Overview

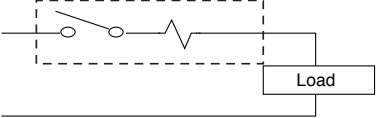
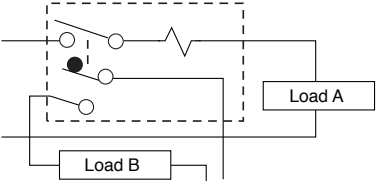
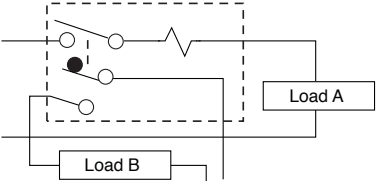
Description	Circuit Example
	<p><b>Series Trip</b> This is the most common circuit breaker, providing overload and short circuit protection. It can also be used as an ON/OFF switch.</p>
	<p><b>Series Trip with Auxiliary Contact</b> Since the auxiliary contact operation is interlocked with the ON/OFF of the main contactor, circuit breaker operation can be monitored by a lamp or buzzer. This circuit breaker can also be used to control auxiliary circuits up to 250V AC/5A (resistive load).</p>
	<p><b>Series Trip with Alarm Contact</b> Since the alarm contact is electrically independent of the main contactor, but actuates when the protective element operates. The alarm can be used with a lamp or buzzer to monitor trip operations, and can also be used for controlling alarm circuits. The contact rating is 250V AC/5A (resistive load).</p>

Applications

The IDEC NRA circuit breaker series features superior overload and short-circuit protection. Many combinations of protection mechanisms and internal circuit connections enable wide applications.

- **Precision measuring instruments:** electronic counters, projection instruments, oscilloscopes, industrial instrumentation, and analytic devices
- **Industrial machinery:** printers, elevators, cranes
- **Chemical and food industry machines:** vacuum devices, wrappers, centrifuges, agitators
- **Machine tools:** mill grinders, drills, presses
- **Business machines:** vending machines, beauty salon equipment, entertainment games
- **Other:** office equipment, air-conditioners, conveyor belts, and many more

How the Breaker Operates

IDEC's hydraulic magnetic circuit breakers operate like a solenoid coil. The coil unit consists of an oil-filled tube with a metal core at one end and a pole piece and armature at the opposite end with a spring in between.

When a current load passes through the coil winding, it creates a magnetic field. As long as the current load is either at or below the nominal rating of the breaker, the metal core will remain stationary.

If the current load increases beyond the nominal rating, the strength of the magnetic field causes the core to move toward the pole-end of the tube. The oil viscosity regulates the core's movement through the tube, thereby regulating the time delay. As the percentage of current load increases, the required trip time of the breaker decreases and vice versa.

When the current reaches the overload rating, the metal core will meet the pole piece at the opposite end of the tube. At this point, the armature is attracted to the same pole piece, tripping the breaker.

In case of sudden short circuit, the magnetic field created will instantly trip the breaker.