

Hazardous Area LED Lighting
Champ® FMV LED Luminaires

CROUSE-HINDS
SERIES

Champ® FMV

LED floodlights for harsh and hazardous areas



EATON

Powering Business Worldwide

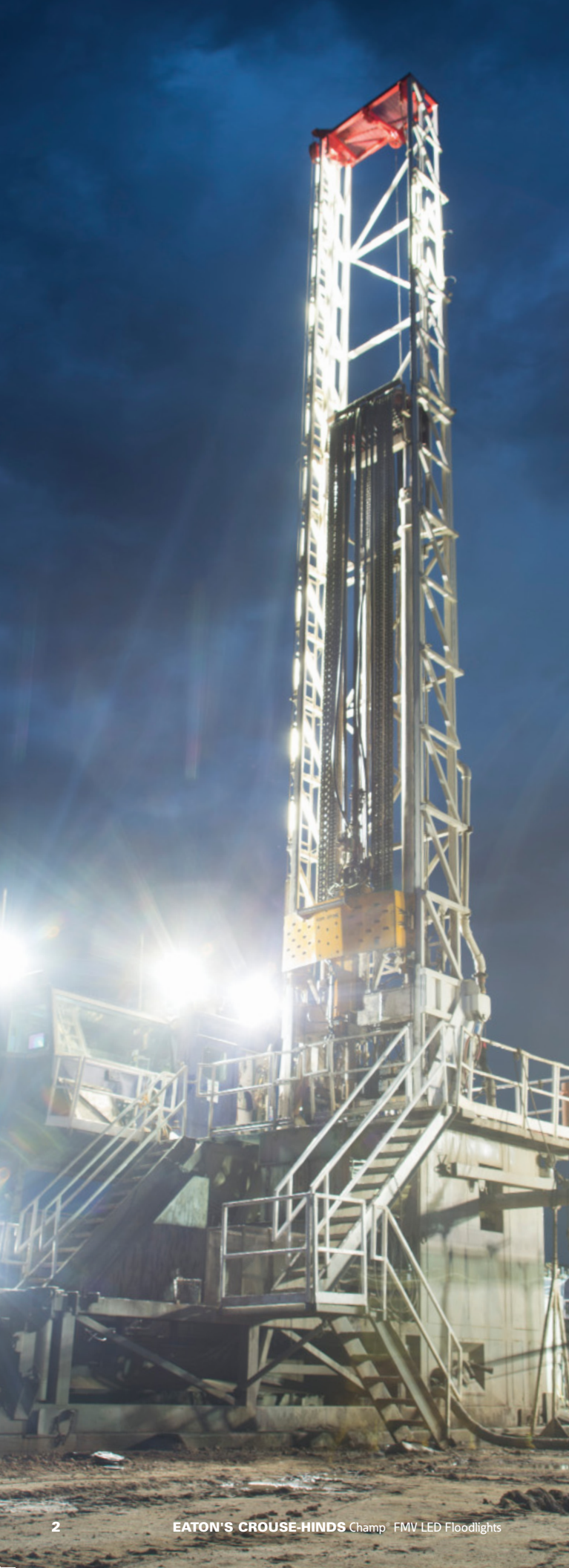

Champ® FMV LED floodlights

Safe. Reliable. Efficient.

Featuring the industry's broadest range of LED luminaires for harsh, hazardous and industrial environments, Eaton's Crouse-Hinds can deliver a lighting solution that performs reliably in even the worst operating conditions. All the while reducing your energy, maintenance and manpower costs.

Why LED?

Energy efficiency

LED average energy consumption is significantly less than traditional fluorescent and HID fixtures

Start/restart time

Instant illumination vs. 10 minute restrike time for HID

Light quality

Higher color rendering compared to fluorescent and HID

Environmental benefits

Mercury-free LED eliminates disposal costs and lower energy consumption for a smaller carbon footprint

Why Crouse-Hinds?

Industry-best reliability

Built to withstand a wide array of applications

Thermal management

Effective heat sinking ensures longer life

Quality of light

Custom optics designed to maximize light distribution and intensity

Globally certified

Designed to global specifications for IEC and NEC applications

Serviceable drivers

Easy access to drivers for service or replacement

Why FMV LED?

Reliable floodlights. FMV LED luminaires are engineered to deliver high lumen output and maintenance-free long life in the toughest conditions.

Versatile design

- Can be used for outdoor or indoor applications, and for a wide range of mounting heights depending on model and light level requirement

Smaller and lighter

- 25% smaller footprint than previous model
- 10 lbs. (4.5 kg) less weight than previous model

Full frame yoke

- Designed to utilize the SFA6 slipfitter and SWB6 wall mount bracket, making it ideal for retrofit or new installations



High lumen output:

- Up to 117 lumens per watt
- Up to 72% energy savings over traditional HID fixtures (compared to 400W MH)



Multiple lens options:

- Tempered clear glass lens standard
- Polycarbonate and diffused glass lens options available

Rugged heat sink

- Heat sink designed to perform and provide maximum light levels in high ambient temperatures up to +65°C and as low as -40°C
- Thick walled castings make for a tough, rugged housing that keeps the internal driver and LED temperature down

LED vs. HID savings at a glance

Why are so many facilities making the switch from HID to LED?

The numbers say it all.

FMV13L/UNV1 vs. 400 watt HID

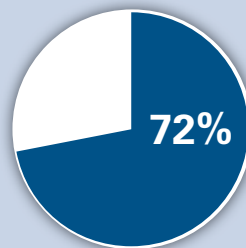

72% REDUCTION IN ENERGY COSTS

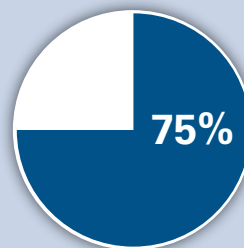

75% LOWER TOTAL COST OF OWNERSHIP



100% MAINTENANCE REDUCTION

Assumptions: Calculations based on overall life of the LED system. Energy cost of \$.09 per kilowatt; 24 hour per day operation; labor rate of \$75 each for 2 workers; average time for fixture maintenance of 1 hour.

Features & specifications

Champ FMV LED floodlights

Champ FMV LED floodlights are designed to provide full-spectrum, crisp, white light. Seven versions of the Champ FMV are available, from 3,000 to 15,000 lumens, providing ideal solutions for a wide range of harsh and hazardous applications.

Up to 75% reduction in energy costs and 150,000 hours of continuous operation.

Model number	Nominal lumens*	Wattage	Lumens per watt	Equivalent HID luminaire
FMV3L	3,189	28	114	70W-100W
FMV5L	5,183	45	115	100W-150W
FMV7L	7,095	62	114	150W-175W
FMV9L	9,132	79	116	175W-250W
FMV11L	11,107	99	112	250W-400W
FMV13L	13,100	112	117	400W
FMV15L	15,181	131	116	450W

*Tolerance +/- 10%; @120 VAC, 25°C ambient, 7x6 optics.

Applications:

- Oil and gas refineries, drilling rigs, petrochemical facilities, food and beverage facilities, platforms, loading docks, tunnels, outdoor wall and stanchion mounted general area lighting, and where flammable vapors, gases, ignitable dusts, fibers or flyings are present
- Locations requiring continuous and consistent light levels in extreme ambient temperatures
- Where extremely corrosive, wet, dusty, hot and/or cold conditions exist
- IP66, Type 4X, marine, wet locations and hose-down environments
- Classified and hazardous locations

LED system:

- Cool white (5000K, 70 CRI) and warm white (3000K, 80 CRI)
- Custom designed optics – 7x6 standard, 3x3 optional (3L-11L)

Champ FMV LED benefits:

- Instant illumination and restrike
- Better visibility with crisp, white light
- Cold temperature operation / no warm-up required
- Minimum T3C temperature rating – safely operate in the most hazardous environments and any non-hazardous location
- Serviceable drivers
- Easy installation – yoke design to mount to SFA6
- Energy-efficient technology – up to 72% energy savings over HID fixtures
- 60,000 hours of rated life at 55°C – eliminates need for frequent lamp replacement
- Contains no mercury or other hazardous substances
- Shock- and vibration-resistant solid-state luminaires have no filaments or glass components that could break – greatly reduces the risk of premature failure
- Operating ambient -40°C to 65°C (NEC only; IEC -40°C to 55°C)
- 5 year fixture warranty†

†Extension of standard terms and conditions to five years. Refer to page 2 of the D-0914 authorized distributor price book for Crouse-Hinds standard Terms and Conditions.

LED system lifetime rated versus economic life:

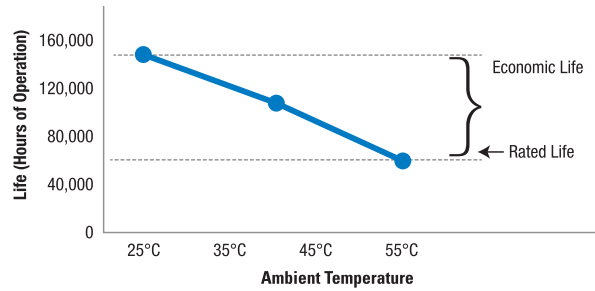

Economic life can range anywhere between 50,000 to 150,000 hours, or 5 to 20 years of maintenance-free operation.

Fixture life and years of maintenance-free operation

Ambient temperature	Fixture life (hours)	No. of years at 24 hours usage	No. of years at 12 hours usage
25°C	150,000	17	34
40°C	90,000	10	20
55°C	60,000	7	14

*50,000 hours of life at 65°C ambient.

Fixture life:

- Rated life of 60,000 hours @ 55°C operating ambient and 24/7 continuous operation for 365 days
- Economic life of 150,000 hours @ 25°C ambient
- L70 LED life >300,000 hours @ 55°C

Electrical ratings:

Model number	Input power (watts)	Input amps at 120-277 VAC
FMV3L	28.0 - 29.1	0.24 - 0.11
FMV5L	45.4 - 45.8	0.38 - 0.18
FMV7L	61.8 - 62.5	0.52 - 0.24
FMV9L	78.8 - 80.3	0.66 - 0.31
FMV11L	98.8 - 99.9	0.83 - 0.37
FMV13L	111.8 - 112.4	0.94 - 0.42
FMV15L	131.4 - 131.5	1.10 - 0.48

FMV3L - FMV15L

Voltage range, VAC*	100-277V @ 50/60 Hz, 347-480V @ 50/60 Hz
Voltage range, VDC*	108-250V
Power factor	>0.9

*NEC voltage; see drivers below for IEC voltage.

Standard materials:

- Lamp housing and adapter – die cast aluminum with Corro-free™ epoxy powder coat
- Lens – heat- and impact-resistant glass (standard)
- Gaskets – silicone and neoprene
- External hardware – stainless steel

Qualifications and compliances:

- DesignLights Consortium® Qualified (some models are not DLC qualified)*



* Approved models include: FMV3L/UNV1; FMV5L/UNV1; FMV7L/UNV1; FMV9L/UNV1; FMV11L/UNV1; FMV13L/UNV1; FMV3L/UNV34; FMV5L/UNV34; FMV7L/UNV34; FMV9L/UNV34; FMV11L/UNV34; FMV13L/UNV34

7x6 optics on all approved models; 3x3 optics not DLC approved.

Refer to www.designlights.org Qualified Products List under family models for full listing details. Not all models are approved for all application categories.

Certifications and compliances:

NEC and CEC:

- Class I, Division 2, Groups A, B, C, D; Class I, Zone 2; Class II, Groups E, F, G; Simultaneous Presence; Class III
- Type 4X, IP66

UL Standards:

- UL844; UL1598; UL1598A; UL8750

CSA Standard:

- CSA C22.2 No. 137

IEC Standards:

- IECEx UL 15.0029
- Ex nA IIC T5 Gc Tamb -40°C to +40°C
- Ex nA IIC T4 Gc Tamb -40°C to +55°C
- Ex tb IIIC T65 Db Tamb -40°C to +40°C
- Ex tb IIIC T80 Db Tamb -40°C to +55°C

ATEX/CE:

- CE 0359 DEMKO 15 ATEX 1377
- CE 0359 DEMKO 15 ATEX 1383
- II 3 G Ex nA IIC T5 Gc Tamb -40°C to +40°C
- II 3 G Ex nA IIC T4 Gc Tamb -40°C to +55°C
- II 2 D Ex tb IIIC T65 Db Tamb -40°C to +40°C
- II 2 D Ex tb IIIC T80 Db Tamb -40°C to +55°C



Temperature codes:

Model	Ambient temperature	Simultaneous rating							Minimum wire temperature
		Class I, Div. 2	Class II, Div. 1	Class I, Div. 2, Div. 1	Class I, Zone 2	ATEX 3G	ATEX 2D		
FMV3L-FMV15L	40°C	T5	T4	T4	T5	T5	T65	90°C	
	55°C	T4A	T3C	T3C	T4	T4	T80	90°C	
	65°C	T4A	T3C	T3C	T4	—	—	90°C	

Weights and dimensions:

Model number	Lbs.	Kg.	Width		Height		Depth	
			in.	mm.	in.	mm.	in.	mm.
FMV3L-FMV7L	30.7	13.9	15.5	393.7	12.0	304.8	7.0	177.8
FMV9L-FMV15L	31.8	14.4	15.5	393.7	12.0	304.8	7.0	177.8

Drivers:

Option	FMV3L - FMV15L
/UNV1	NEC: 100-277 VAC, 50/60 Hz; 108-250 VDC IEC: 100-252 VAC, 50/60 Hz; 111-227 VDC
/UNV34	NEC: 347-480 VAC, 50/60 Hz IEC: 385-436 VAC, 50/60 Hz

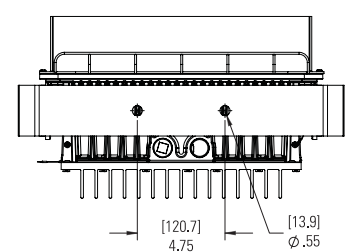
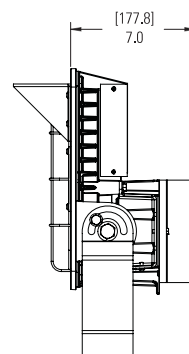
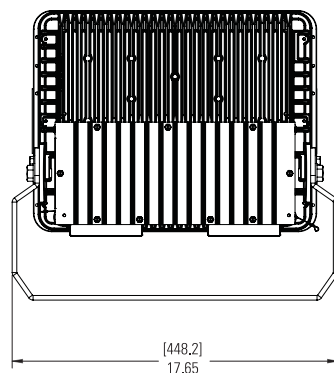
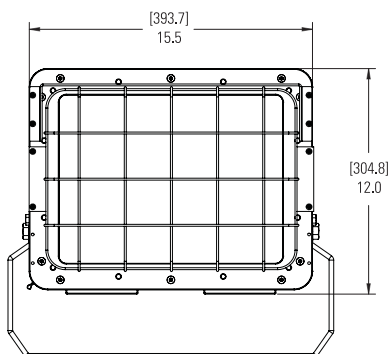

Ordering information

Part number example

FMV5LCY/UNV1D 76 S903

FMV 5L C Y /UNV1 D 76 S903

Model

FMV NEC & IEC model

Mount

Y Yoke

Light source/intensity

3L	3,189 nominal lumens*
5L	5,183 nominal lumens*
7L	7,095 nominal lumens*
9L	9,132 nominal lumens*
11L	11,107 nominal lumens*
13L	13,100 nominal lumens*
15L	15,181 nominal lumens*

*7x6 model.

Color temperature

C	5000K, 70 CRI (cool white)
W	3000K, 80 CRI (warm white)

Voltage

/UNV1	100-277 VAC, 50/60 Hz; 108-250 VDC
/UNV34	347-480 VAC 50/60 Hz

Options

S886	Two TMCX cable glands of like thread installed
S891	Diffused glass lens
S903	Polycarbonate lens

Entries

BLANK	¾" NPT
M20	20mm entry
M25	25mm entry

Optical distribution

76	7x6 floodlight pattern optics
33*	3x3 floodlight pattern optics

*3L - 11L only.

Dimming

D*	Dimmable driver
BLANK	Non-dimmable driver

*Dimmable driver option only available for NEC rated models.

Accessories (ordered separately)

DSV2	Bolt-on visor
P62	Bolt-on wire guard
SC831	Safety cable
SFA6	Floodlight slipfitter
SWB6	Slipfitter wall mount adapter

Photometric data

7x6 optics

FMV13L Height: 40 ft.; Tilt angle: 45°

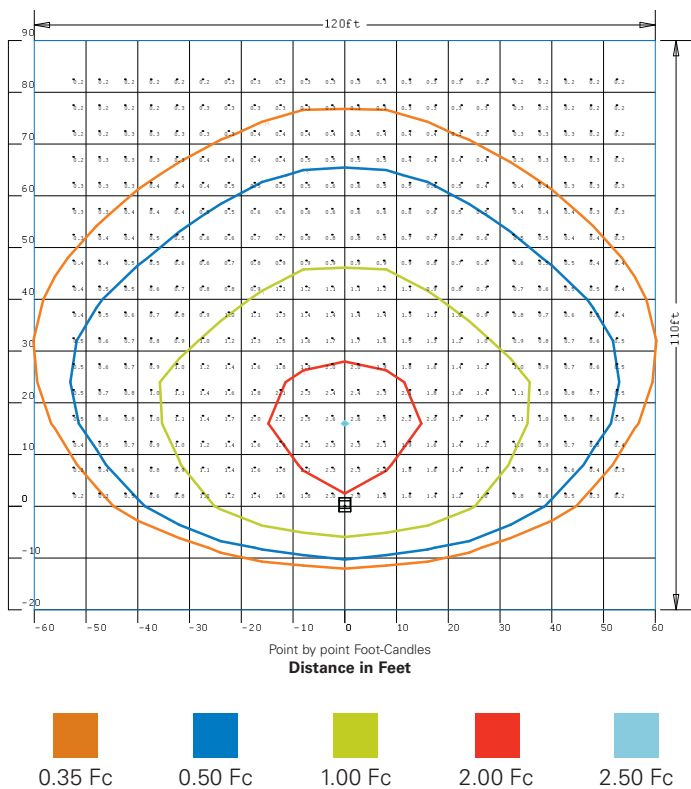

3x3 optics

FMV11L Height: 30 ft.; Tilt angle: 45°

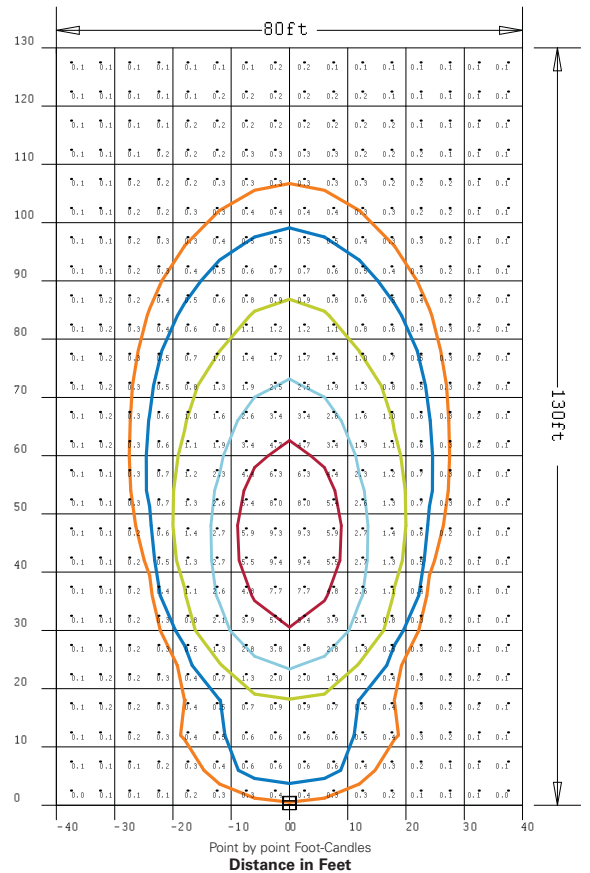

Effective projected area (ft.-sq.):

Position	FMV3L - FMV15L
@ 0° Tilt	1.5
@ 45° Backwards tilt	1.1
@ 60° Forward tilt	0.8

Lumen output for glass lens models

Optic	FMV3L	FMV5L	FMV7L	FMV9L	FMV11L	FMV13L	FMV15L
7x6	3,189	5,183	7,095	9,132	11,107	13,100	15,181
3x3	3,064	5,038	7,000	8,962	10,917	-	-

Lumen output for diffused glass lens (S891) models

Optic	FMV3L	FMV5L	FMV7L	FMV9L	FMV11L	FMV13L	FMV15L
7x6	2,637	4,287	5,878	7,459	8,994	10,613	12,445
3x3	2,546	4,179	5,806	7,433	9,055	-	-

Lumen output for polycarbonate lens (S903) models

Optic	FMV3L	FMV5L	FMV7L	FMV9L	FMV11L	FMV13L	FMV15L
7x6	3,017	4,903	6,712	8,639	10,507	12,393	14,361
3x3	2,924	4,808	6,680	8,552	10,418	-	-



Higher average footcandles/lux, uniformity and distribution coverage with **72% less energy consumption** compared to 400W metal halide.

**U.S. (global headquarters):
Eaton's Crouse-Hinds business**

1201 Wolf Street
Syracuse, NY 13208

(866) 764-5454
FAX: (315) 477-5179
FAX Orders Only:
(866) 653-0640

crousecustomerctr@eaton.com

For more information:

If further assistance is required, please contact an authorized Eaton Distributor, Sales Office, or Customer Service Department.

Canada

Toll Free: 800-265-0502
FAX: (800) 263-9504
FAX Orders only: (866) 653-0645

Mexico/Latin America/Caribbean

52-555-804-4000
FAX: 52-555-804-4020
ventascentromex@eaton.com

Europe (Germany)

49 (0) 6271 806-500
49 (0) 6271 806-476
sales.CCH.de@cooperindustries.com

Eaton Middle East

9714-8066100
FAX: 9714-8894813
chmesales@eaton.com

Singapore

65-6645-9888
FAX: 65-6297-4819
chsi-sales@cooperindustries.com

China

86-21-2899-3600
FAX: 86-21-2899-4055
cchsales@cooperindustries.com

Korea

82-2-3484-6783
82-2-3484-6778
CCHK-sales@cooperindustries.com

Australia

61-2-8787-2777
FAX: 61-2-9609-2342
CEASales@cooperindustries.com

India

91-124-4683888
FAX: 91-124-4683899
cchindia@eaton.com

Eaton's Crouse-Hinds
1201 Wolf Street
Syracuse, NY 13208
Crouse-Hinds.com

Eaton
1000 Eaton Boulevard
Cleveland, OH 44122
United States
Eaton.com

© 2015 Eaton
All Rights Reserved
Printed in USA
Publication No. 5242-1215
December 2015

Eaton is a registered trademark.
All other trademarks are property of their respective owners.

Hazardous Area LED Lighting
Champ® FMV LED Luminaires

CROUSE-HINDS
SERIES

Champ® FMV

LED floodlights for harsh and hazardous areas



EATON

Powering Business Worldwide

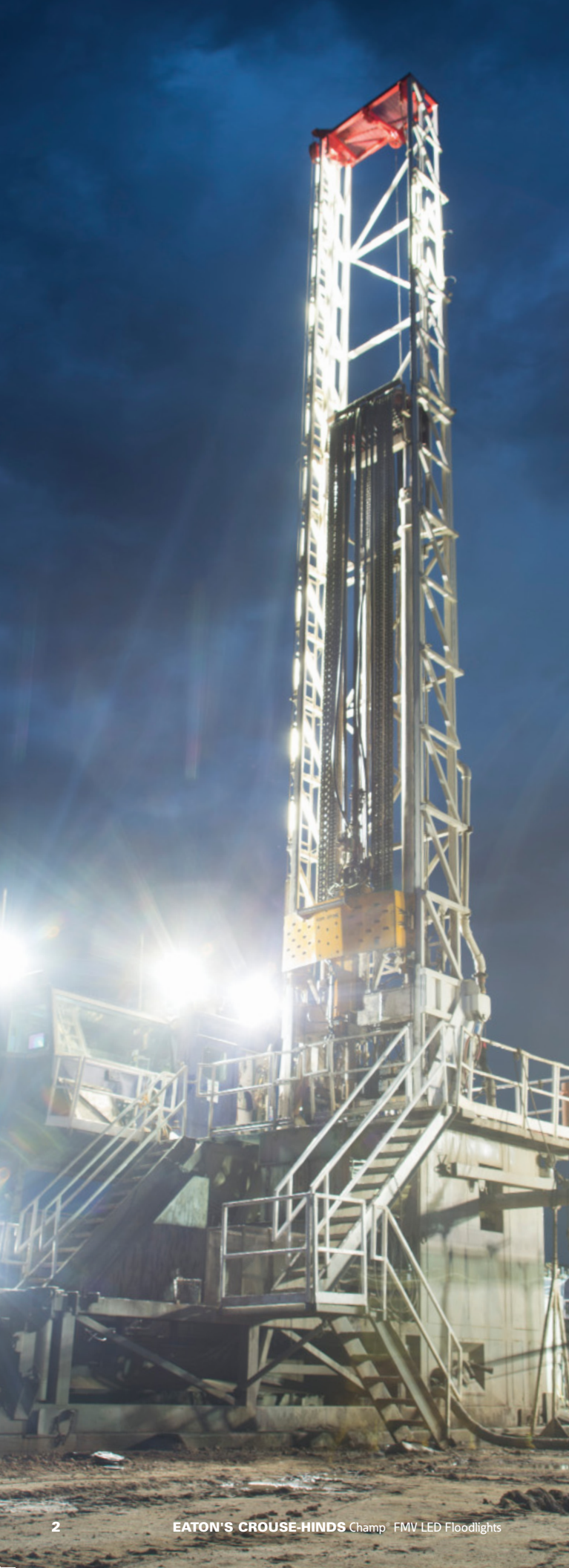

Champ® FMV LED floodlights

Safe. Reliable. Efficient.

Featuring the industry's broadest range of LED luminaires for harsh, hazardous and industrial environments, Eaton's Crouse-Hinds can deliver a lighting solution that performs reliably in even the worst operating conditions. All the while reducing your energy, maintenance and manpower costs.

Why LED?

Energy efficiency

LED average energy consumption is significantly less than traditional fluorescent and HID fixtures

Start/restart time

Instant illumination vs. 10 minute restrike time for HID

Light quality

Higher color rendering compared to fluorescent and HID

Environmental benefits

Mercury-free LED eliminates disposal costs and lower energy consumption for a smaller carbon footprint

Why Crouse-Hinds?

Industry-best reliability

Built to withstand a wide array of applications

Thermal management

Effective heat sinking ensures longer life

Quality of light

Custom optics designed to maximize light distribution and intensity

Globally certified

Designed to global specifications for IEC and NEC applications

Serviceable drivers

Easy access to drivers for service or replacement

Why FMV LED?

Reliable floodlights. FMV LED luminaires are engineered to deliver high lumen output and maintenance-free long life in the toughest conditions.

Versatile design

- Can be used for outdoor or indoor applications, and for a wide range of mounting heights depending on model and light level requirement

Smaller and lighter

- 25% smaller footprint than previous model
- 10 lbs. (4.5 kg) less weight than previous model

Full frame yoke

- Designed to utilize the SFA6 slipfitter and SWB6 wall mount bracket, making it ideal for retrofit or new installations



High lumen output:

- Up to 117 lumens per watt
- Up to 72% energy savings over traditional HID fixtures (compared to 400W MH)



Multiple lens options:

- Tempered clear glass lens standard
- Polycarbonate and diffused glass lens options available

Rugged heat sink

- Heat sink designed to perform and provide maximum light levels in high ambient temperatures up to +65°C and as low as -40°C
- Thick walled castings make for a tough, rugged housing that keeps the internal driver and LED temperature down

LED vs. HID savings at a glance

Why are so many facilities making the switch from HID to LED?

The numbers say it all.

FMV13L/UNV1 vs. 400 watt HID

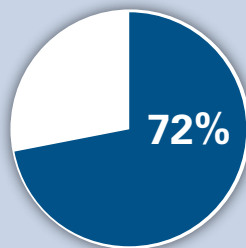

72% REDUCTION IN ENERGY COSTS

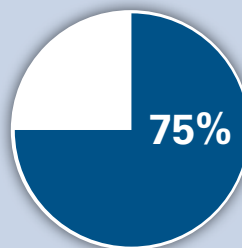

75% LOWER TOTAL COST OF OWNERSHIP



100% MAINTENANCE REDUCTION

Assumptions: Calculations based on overall life of the LED system. Energy cost of \$.09 per kilowatt; 24 hour per day operation; labor rate of \$75 each for 2 workers; average time for fixture maintenance of 1 hour.

Features & specifications

Champ FMV LED floodlights

Champ FMV LED floodlights are designed to provide full-spectrum, crisp, white light. Seven versions of the Champ FMV are available, from 3,000 to 15,000 lumens, providing ideal solutions for a wide range of harsh and hazardous applications.

Up to 75% reduction in energy costs and 150,000 hours of continuous operation.

Model number	Nominal lumens*	Wattage	Lumens per watt	Equivalent HID luminaire
FMV3L	3,189	28	114	70W-100W
FMV5L	5,183	45	115	100W-150W
FMV7L	7,095	62	114	150W-175W
FMV9L	9,132	79	116	175W-250W
FMV11L	11,107	99	112	250W-400W
FMV13L	13,100	112	117	400W
FMV15L	15,181	131	116	450W

*Tolerance +/- 10%; @120 VAC, 25°C ambient, 7x6 optics.

Applications:

- Oil and gas refineries, drilling rigs, petrochemical facilities, food and beverage facilities, platforms, loading docks, tunnels, outdoor wall and stanchion mounted general area lighting, and where flammable vapors, gases, ignitable dusts, fibers or flyings are present
- Locations requiring continuous and consistent light levels in extreme ambient temperatures
- Where extremely corrosive, wet, dusty, hot and/or cold conditions exist
- IP66, Type 4X, marine, wet locations and hose-down environments
- Classified and hazardous locations

LED system:

- Cool white (5000K, 70 CRI) and warm white (3000K, 80 CRI)
- Custom designed optics – 7x6 standard, 3x3 optional (3L-11L)

Champ FMV LED benefits:

- Instant illumination and restrike
- Better visibility with crisp, white light
- Cold temperature operation / no warm-up required
- Minimum T3C temperature rating – safely operate in the most hazardous environments and any non-hazardous location
- Serviceable drivers
- Easy installation – yoke design to mount to SFA6
- Energy-efficient technology – up to 72% energy savings over HID fixtures
- 60,000 hours of rated life at 55°C – eliminates need for frequent lamp replacement
- Contains no mercury or other hazardous substances
- Shock- and vibration-resistant solid-state luminaires have no filaments or glass components that could break – greatly reduces the risk of premature failure
- Operating ambient -40°C to 65°C (NEC only; IEC -40°C to 55°C)
- 5 year fixture warranty†

†Extension of standard terms and conditions to five years. Refer to page 2 of the D-0914 authorized distributor price book for Crouse-Hinds standard Terms and Conditions.

LED system lifetime rated versus economic life:

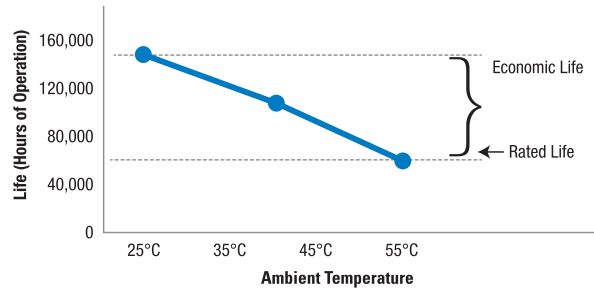

Economic life can range anywhere between 50,000 to 150,000 hours, or 5 to 20 years of maintenance-free operation.

Fixture life and years of maintenance-free operation

Ambient temperature	Fixture life (hours)	No. of years at 24 hours usage	No. of years at 12 hours usage
25°C	150,000	17	34
40°C	90,000	10	20
55°C	60,000	7	14

*50,000 hours of life at 65°C ambient.

Fixture life:

- Rated life of 60,000 hours @ 55°C operating ambient and 24/7 continuous operation for 365 days
- Economic life of 150,000 hours @ 25°C ambient
- L70 LED life >300,000 hours @ 55°C

Electrical ratings:

Model number	Input power (watts)	Input amps at 120-277 VAC
FMV3L	28.0 - 29.1	0.24 - 0.11
FMV5L	45.4 - 45.8	0.38 - 0.18
FMV7L	61.8 - 62.5	0.52 - 0.24
FMV9L	78.8 - 80.3	0.66 - 0.31
FMV11L	98.8 - 99.9	0.83 - 0.37
FMV13L	111.8 - 112.4	0.94 - 0.42
FMV15L	131.4 - 131.5	1.10 - 0.48

FMV3L - FMV15L

Voltage range, VAC*	100-277V @ 50/60 Hz, 347-480V @ 50/60 Hz
Voltage range, VDC*	108-250V
Power factor	>0.9

*NEC voltage; see drivers below for IEC voltage.

Standard materials:

- Lamp housing and adapter – die cast aluminum with Corro-free™ epoxy powder coat
- Lens – heat- and impact-resistant glass (standard)
- Gaskets – silicone and neoprene
- External hardware – stainless steel

Qualifications and compliances:

- DesignLights Consortium® Qualified (some models are not DLC qualified)*



* Approved models include: FMV3L/UNV1; FMV5L/UNV1; FMV7L/UNV1; FMV9L/UNV1; FMV11L/UNV1; FMV13L/UNV1; FMV3L/UNV34; FMV5L/UNV34; FMV7L/UNV34; FMV9L/UNV34; FMV11L/UNV34; FMV13L/UNV34

7x6 optics on all approved models; 3x3 optics not DLC approved.

Refer to www.designlights.org Qualified Products List under family models for full listing details. Not all models are approved for all application categories.

Certifications and compliances:

NEC and CEC:

- Class I, Division 2, Groups A, B, C, D; Class I, Zone 2; Class II, Groups E, F, G; Simultaneous Presence; Class III
- Type 4X, IP66

UL Standards:

- UL844; UL1598; UL1598A; UL8750

CSA Standard:

- CSA C22.2 No. 137

IEC Standards:

- IECEx UL 15.0029
- Ex nA IIC T5 Gc Tamb -40°C to +40°C
- Ex nA IIC T4 Gc Tamb -40°C to +55°C
- Ex tb IIIC T65 Db Tamb -40°C to +40°C
- Ex tb IIIC T80 Db Tamb -40°C to +55°C

ATEX/CE:

- CE_{0359} DEMKO 15 ATEX 1377
- CE_{0359} DEMKO 15 ATEX 1383
- II 3 G Ex nA IIC T5 Gc Tamb -40°C to +40°C
- II 3 G Ex nA IIC T4 Gc Tamb -40°C to +55°C
- II 2 D Ex tb IIIC T65 Db Tamb -40°C to +40°C
- II 2 D Ex tb IIIC T80 Db Tamb -40°C to +55°C



Temperature codes:

Model	Ambient temperature	Simultaneous rating						
		Class I, Div. 2	Class II, Div. 1	Class I, Div. 2, Div. 1	Class I, Zone 2	ATEX 3G	ATEX 2D	Minimum wire temperature
FMV3L-FMV15L	40°C	T5	T4	T4	T5	T5	T65	90°C
	55°C	T4A	T3C	T3C	T4	T4	T80	90°C
	65°C	T4A	T3C	T3C	T4	—	—	90°C

Weights and dimensions:

Model number	Lbs.	Kg.	Width		Height		Depth	
			in.	mm.	in.	mm.	in.	mm.
FMV3L-FMV7L	30.7	13.9	15.5	393.7	12.0	304.8	7.0	177.8
FMV9L-FMV15L	31.8	14.4	15.5	393.7	12.0	304.8	7.0	177.8

Drivers:

Option	FMV3L - FMV15L
/UNV1	NEC: 100-277 VAC, 50/60 Hz; 108-250 VDC IEC: 100-252 VAC, 50/60 Hz; 111-227 VDC
/UNV34	NEC: 347-480 VAC, 50/60 Hz IEC: 385-436 VAC, 50/60 Hz

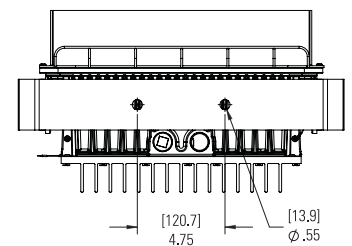
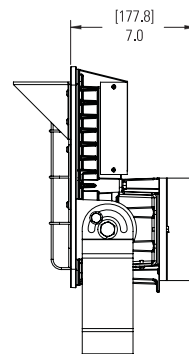
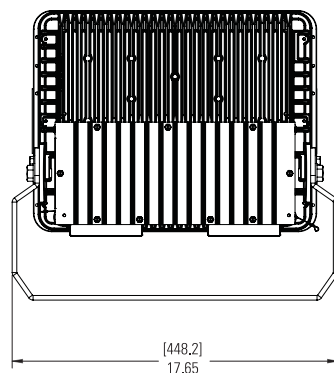
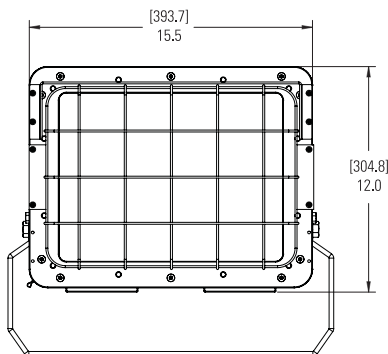

Ordering information

Part number example

FMV5LCY/UNV1D 76 S903

FMV 5L C Y /UNV1 D 76 S903

Model

FMV NEC & IEC model

Mount

Y Yoke

Light source/intensity

3L	3,189 nominal lumens*
5L	5,183 nominal lumens*
7L	7,095 nominal lumens*
9L	9,132 nominal lumens*
11L	11,107 nominal lumens*
13L	13,100 nominal lumens*
15L	15,181 nominal lumens*

*7x6 model.

Color temperature

C	5000K, 70 CRI (cool white)
W	3000K, 80 CRI (warm white)

Voltage

/UNV1	100-277 VAC, 50/60 Hz; 108-250 VDC
/UNV34	347-480 VAC 50/60 Hz

Options

S886	Two TMCX cable glands of like thread installed
S891	Diffused glass lens
S903	Polycarbonate lens

Entries

BLANK	¾" NPT
M20	20mm entry
M25	25mm entry

Optical distribution

76	7x6 floodlight pattern optics
33*	3x3 floodlight pattern optics

*3L - 11L only.

Dimming

D*	Dimmable driver
BLANK	Non-dimmable driver

*Dimmable driver option only available for NEC rated models.

Accessories (ordered separately)

DSV2	Bolt-on visor
P62	Bolt-on wire guard
SC831	Safety cable
SFA6	Floodlight slipfitter
SWB6	Slipfitter wall mount adapter

Photometric data

7x6 optics

FMV13L Height: 40 ft.; Tilt angle: 45°

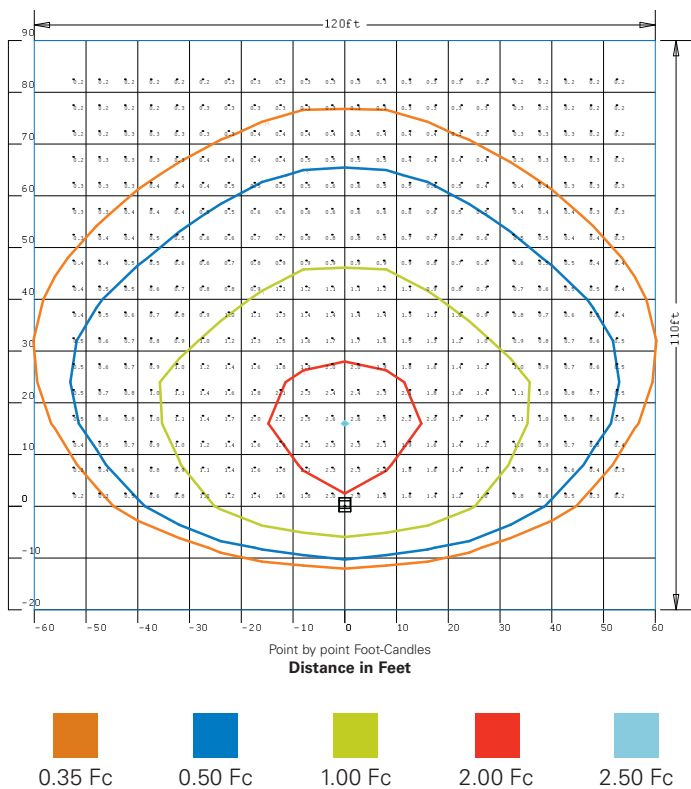

3x3 optics

FMV11L Height: 30 ft.; Tilt angle: 45°

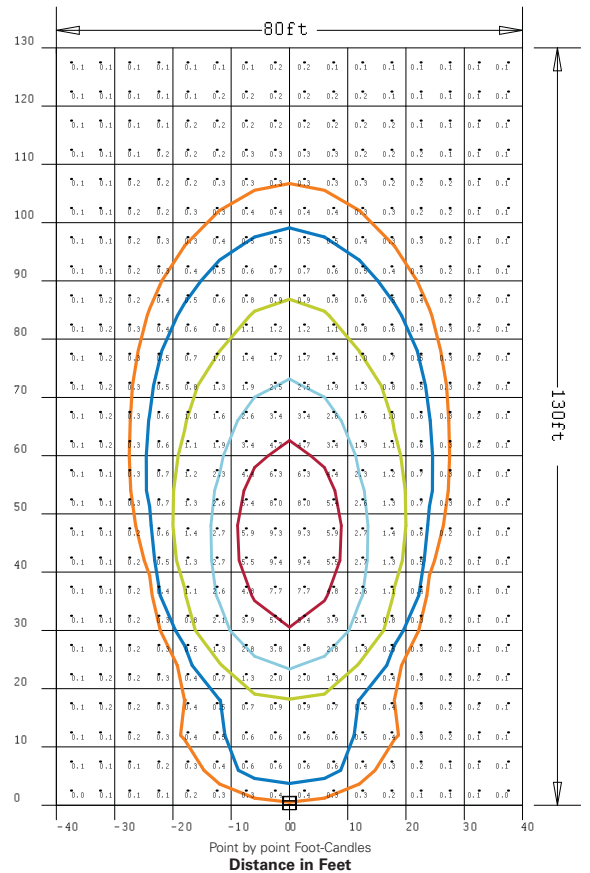

Effective projected area (ft.-sq.):

Position	FMV3L - FMV15L
@ 0° Tilt	1.5
@ 45° Backwards tilt	1.1
@ 60° Forward tilt	0.8

Lumen output for glass lens models

Optic	FMV3L	FMV5L	FMV7L	FMV9L	FMV11L	FMV13L	FMV15L
7x6	3,189	5,183	7,095	9,132	11,107	13,100	15,181
3x3	3,064	5,038	7,000	8,962	10,917	-	-

Lumen output for diffused glass lens (S891) models

Optic	FMV3L	FMV5L	FMV7L	FMV9L	FMV11L	FMV13L	FMV15L
7x6	2,637	4,287	5,878	7,459	8,994	10,613	12,445
3x3	2,546	4,179	5,806	7,433	9,055	-	-

Lumen output for polycarbonate lens (S903) models

Optic	FMV3L	FMV5L	FMV7L	FMV9L	FMV11L	FMV13L	FMV15L
7x6	3,017	4,903	6,712	8,639	10,507	12,393	14,361
3x3	2,924	4,808	6,680	8,552	10,418	-	-



Higher average footcandles/lux, uniformity and distribution coverage with **72% less energy consumption** compared to 400W metal halide.

**U.S. (global headquarters):
Eaton's Crouse-Hinds business**

1201 Wolf Street
Syracuse, NY 13208

(866) 764-5454
FAX: (315) 477-5179
FAX Orders Only:
(866) 653-0640

crousecustomerctr@eaton.com

For more information:

If further assistance is required, please contact an authorized Eaton Distributor, Sales Office, or Customer Service Department.

Canada

Toll Free: 800-265-0502
FAX: (800) 263-9504
FAX Orders only: (866) 653-0645

Mexico/Latin America/Caribbean

52-555-804-4000
FAX: 52-555-804-4020
ventascentromex@eaton.com

Europe (Germany)

49 (0) 6271 806-500
49 (0) 6271 806-476
sales.CCH.de@cooperindustries.com

Eaton Middle East

9714-8066100
FAX: 9714-8894813
chmesales@eaton.com

Singapore

65-6645-9888
FAX: 65-6297-4819
chsi-sales@cooperindustries.com

China

86-21-2899-3600
FAX: 86-21-2899-4055
cchsales@cooperindustries.com

Korea

82-2-3484-6783
82-2-3484-6778
CCHK-sales@cooperindustries.com

Australia

61-2-8787-2777
FAX: 61-2-9609-2342
CEASales@cooperindustries.com

India

91-124-4683888
FAX: 91-124-4683899
cchindia@eaton.com

Eaton's Crouse-Hinds
1201 Wolf Street
Syracuse, NY 13208
Crouse-Hinds.com

Eaton
1000 Eaton Boulevard
Cleveland, OH 44122
United States
Eaton.com

© 2015 Eaton
All Rights Reserved
Printed in USA
Publication No. 5242-1215
December 2015

Eaton is a registered trademark.
All other trademarks are property of their respective owners.