

Specification Submittal Data / Panasonic Precision Spot Ventilation Fan

Description:

Ventilating fan shall be Low Noise ceiling mount type rated for continuous run. Fan shall be ENERGY STAR® rated and certified by the Home Ventilation Institute (HVI). Evaluated by Underwriters Laboratories and conform to both UL and cUL safety standards.

Motor/Blower:

- Enclosed brushless ECM motor technology rated for continuous run.
- Fan ventilation rates shall be manually adjustable for 50-80-110 CFM.
- Power rating shall be 120 volts and 60 Hz.
- Fan shall be UL and cUL listed for tub/shower enclosure when GFCI protected.
- Motor equipped with thermal-cutoff fuse.
- Removable with permanently lubricated plug-in motor.

Housing:

- 26 gauge Zinc-Aluminum-Magnesium (ZAM) housing
- Integrated dual 4" or 6" diameter duct adapter.
- Built-in damper reduces back drafting and helps with blower door testing.
- Built-in metal flange provides blocking for penetrations through drywall as an Air Barrier, and assists with the decrease in leakage in the Building Envelope during blower door testing.
- Articulating and expandable installation bracket up to 24".

Ceiling Radiation Damper:

- WhisperCeiling® DC™ is UL listed for use with the Panasonic Ceiling Radiation Damper (Model #: PC-RD05C5, sold separately).

Grille:

- Attractive design using Poly Pro material.
- Attaches directly to housing with torsion springs.

Warranty:

- ECM Motor: 6 Years from original purchase date.
- ALL Parts: 3 Years from original purchase date.

Architectural Specifications:

Ventilation fan shall be UL and cUL listed for ceiling mount and tub/shower enclosure when GFCI protected. Fan shall also be ENERGY STAR® certified, with a built-in speed selector. Choose from 50-80-110 CFM and no more than <0.3/<0.3/<0.3 sone as certified by the Home Ventilating Institute (HVI) at 0.1 static pressure in inches water gauge (w.g.) with no less than 53-83-111 CFM and no more than 0.4/0.6/0.9 sone as certified by HVI at 0.25 w.g. Power Consumption shall be no greater than 4.0/5.9/10.6 watts at 0.1 w.g. and 7.2/10.8/16.4 watts at 0.25 w.g., with efficiency of no less than 12.5/13.6/10.6 CFM/watt at 0.1 w.g. and 7.4/7.7/6.9 CFM/watt at 0.25 w.g. The motor shall be totally enclosed with a brushless ECM motor engineered to

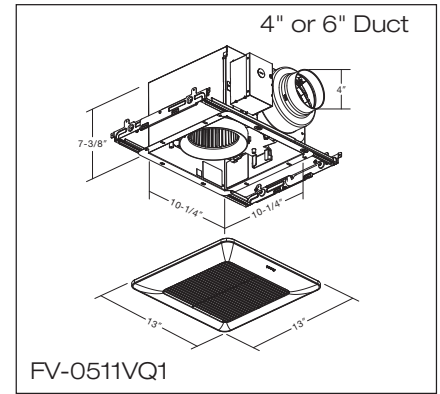

run continuously. ECM motor speed shall automatically increase when the fan senses static pressure to maintain selected CFM. Power rating shall be 120V/60Hz. Duct diameter shall be no less than 4", inclusive of an integrated dual 4" or 6" duct adapter. Fan can be used to comply with ASHRAE 62.2, LEED, ENERGY STAR® IAP, EarthCraft, CA Title 24 and WA state code.

Specifications: WhisperCeiling DC FV-0511VQ1		4"		4"		4"	
Ventilation Fan Characteristics (HVI Certified Data)	Static Pressure in inches w.g.	0.1	0.25	0.1	0.25	0.1	0.25
	Air Volume (CFM)	110	111	80	83	50	53
	Noise (sones)	<0.3	0.9	<0.3	0.6	<0.3	0.4
	Power Consumption (watts)	10.6	16.4	5.9	10.8	4.0	7.2
	Energy Efficiency (CFM/Watt)	10.6	6.9	13.6	7.7	12.5	7.4
	Speed (RPM)	957	1239	821	1172	756	1093
	Current (amps)	0.18	0.26	0.11	0.18	0.07	0.13
	MAX. Current (amps)	0.27					
	Power Rating (V/Hz)	120/60					
	ENERGY STAR rated	Yes					

0.25=Installed Performance

Performance Curve 4" Duct

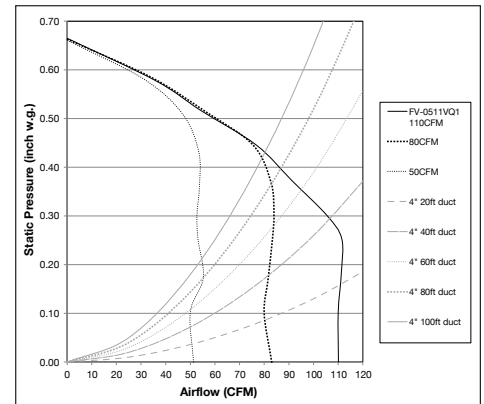

For complete Installation Instructions visit us.panasonic.com/ventfans

Model	Quantity	Comments	Project:
			Location:
			Architect:
			Engineer:
			Contractor:
			Submitted by:
			Date:

Panasonic Eco Solutions North America
Eco Products Division
Two Riverfront Plaza
Newark, NJ 07102



ECM Motor Technology

When the fan senses static pressure, its speed is automatically increased to ensure that the desired CFM is not compromised, which allows the fan to perform as rated.

us.panasonic.com/ventfans



Specification Submittal Data / Panasonic Precision Spot Ventilation Fan

Description:

Ventilating fan shall be Low Noise ceiling mount type rated for continuous run. Fan shall be ENERGY STAR® rated and certified by the Home Ventilation Institute (HVI). Evaluated by Underwriters Laboratories and conform to both UL and cUL safety standards.

Motor/Blower:

- Enclosed brushless ECM motor technology rated for continuous run.
- Fan ventilation rates shall be manually adjustable for 50-80-110 CFM.
- Power rating shall be 120 volts and 60 Hz.
- Fan shall be UL and cUL listed for tub/shower enclosure when GFCI protected.
- Motor equipped with thermal-cutoff fuse.
- Removable with permanently lubricated plug-in motor.

Housing:

- 26 gauge Zinc-Aluminum-Magnesium (ZAM) housing
- Integrated dual 4" or 6" diameter duct adapter.
- Built-in damper reduces back drafting and helps with blower door testing.
- Built-in metal flange provides blocking for penetrations through drywall as an Air Barrier, and assists with the decrease in leakage in the Building Envelope during blower door testing.
- Articulating and expandable installation bracket up to 24".

Ceiling Radiation Damper:

- WhisperCeiling® DC™ is UL listed for use with the Panasonic Ceiling Radiation Damper (Model #: PC-RD05C5, sold separately).

Grille:

- Attractive design using Poly Pro material.
- Attaches directly to housing with torsion springs.

Warranty:

- ECM Motor: 6 Years from original purchase date.
- ALL Parts: 3 Years from original purchase date.

Architectural Specifications:

Ventilation fan shall be UL and cUL listed for ceiling mount and tub/shower enclosure when GFCI protected. Fan shall also be ENERGY STAR® certified, with a built-in speed selector. Choose from 50-80-110 CFM and no more than <0.3/<0.3/<0.3 sone as certified by the Home Ventilating Institute (HVI) at 0.1 static pressure in inches water gauge (w.g.) with no less than 53-83-111 CFM and no more than 0.4/0.6/0.9 sone as certified by HVI at 0.25 w.g. Power Consumption shall be no greater than 4.0/5.9/10.6 watts at 0.1 w.g. and 7.2/10.8/16.4 watts at 0.25 w.g., with efficiency of no less than 12.5/13.6/10.6 CFM/watt at 0.1 w.g. and 7.4/7.7/6.9 CFM/watt at 0.25 w.g. The motor shall be totally enclosed with a brushless ECM motor engineered to

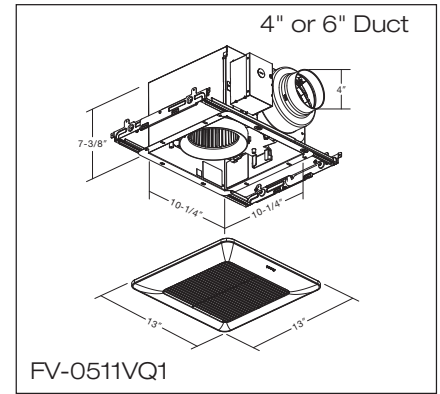

run continuously. ECM motor speed shall automatically increase when the fan senses static pressure to maintain selected CFM. Power rating shall be 120V/60Hz. Duct diameter shall be no less than 4", inclusive of an integrated dual 4" or 6" duct adapter. Fan can be used to comply with ASHRAE 62.2, LEED, ENERGY STAR® IAP, EarthCraft, CA Title 24 and WA state code.

Specifications: WhisperCeiling DC FV-0511VQ1		4"		4"		4"	
Ventilation Fan Characteristics (HVI Certified Data)	Static Pressure in inches w.g.	0.1	0.25	0.1	0.25	0.1	0.25
	Air Volume (CFM)	110	111	80	83	50	53
	Noise (sones)	<0.3	0.9	<0.3	0.6	<0.3	0.4
	Power Consumption (watts)	10.6	16.4	5.9	10.8	4.0	7.2
	Energy Efficiency (CFM/Watt)	10.6	6.9	13.6	7.7	12.5	7.4
	Speed (RPM)	957	1239	821	1172	756	1093
	Current (amps)	0.18	0.26	0.11	0.18	0.07	0.13
	MAX. Current (amps)	0.27					
	Power Rating (V/Hz)	120/60					
	ENERGY STAR rated	Yes					

0.25=Installed Performance

Performance Curve 4" Duct

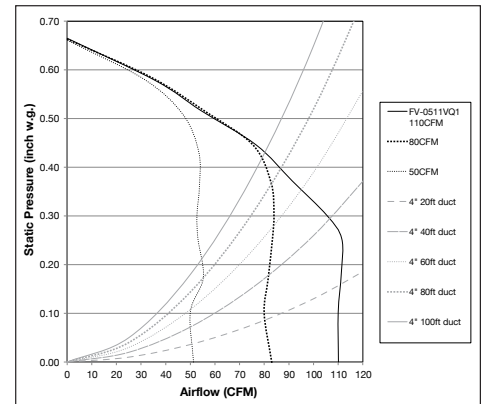

For complete Installation Instructions visit us.panasonic.com/ventfans

Model	Quantity	Comments	Project:
			Location:
			Architect:
			Engineer:
			Contractor:
			Submitted by:
			Date:

Panasonic Eco Solutions North America
Eco Products Division
Two Riverfront Plaza
Newark, NJ 07102



ECM Motor Technology

When the fan senses static pressure, its speed is automatically increased to ensure that the desired CFM is not compromised, which allows the fan to perform as rated.

us.panasonic.com/ventfans

