

Specification Submittal Data / Panasonic Ventilation Fan

Description:

Ventilation fan/LED light shall be low sone ceiling mount rated for continuous run. Fan shall be ENERGY STAR® rated and certified by the Home Ventilating Institute (HVI). Fan shall include energy efficient LED lighting. Evaluated by Underwriters Laboratories and conform to both UL and cUL safety standards.

Motor/Blower:

- Four-pole fully enclosed condenser motor rated for continuous operation.
- Power rating shall be 120 volts and 60 Hz.
- Fan shall be UL listed for tub/shower enclosure when GFCI protected and used in insulated ceiling (TYPE I.C.).
- Motor equipped with thermal-cut-off fuse.
- Removable, permanently lubricated, plug-in motor.

Housing:

- Rust proof epoxy and polyester resin coating, 26 gauge galvanized steel body.
- Integrated dual 4" or 6" diameter duct adapter.
- Metal flange around recessed light aperture helps provide an Air Barrier and assists with the decrease in leakage in the Building Envelope during blower door testing.
- Built in backdraft damper.
- Expandable extension bracket up to 24".
- Double hanger bar system allows for ideal positioning.

Trim Ring:

- Attractive design using Poly Pro material.
- Attaches directly to housing with torsion springs.



(1) 11 Watt GU24 base LED lamp/2700 Kelvin Warm White/>90CRI/750 lumens/68 LPW/ ENERGY STAR 2.0 certified/25,000 hours rated average life.

Light:

- One 11W, ENERGY STAR 2.0 certified, GU24 base LED lamp.
- 2700 Kelvin Warm White/>90CRI/750 lumens/68 LPW/25,000 hour rated average life.
- LED lamp is dimmable.
- FCC Part 15 compliant.

Warranty:

- ALL Parts: 3 Years from original purchase date.
- LED: 5 years from original purchase date.

Architectural Specifications:

Ventilation fan and LED light combination shall be ceiling mount, ENERGY STAR® rated type, with no less than 80 CFM and no more than 1.0 sone as certified by the Home Ventilating Institute (HVI) at 0.1 w.g. with no less than 66 CFM and no more than 0.8 sone at .25 w.g. Power consumption shall be no greater than 18.5 watts at 0.1 w.g. and 17.6 Watts at 0.25 w.g. ENERGY STAR® rated with efficiency of no less than 4.4 CFM/watt at 0.1 w.g. and than 3.8 CFM/watt at 0.25 w.g. The motor shall be fully enclosed, four pole condenser type engineered to operate continuously. Power rating shall be 120v/60Hz. Duct diameter shall be no less than 4", inclusive of an integrated dual 4" or 6" duct adapter. Fan shall be UL and cUL listed for tub/shower enclosure when GFCI protected. Fan housing shall be Type IC. Fan can be used to comply with ASHRAE 62.2, LEED, CALGreen*, ENERGY STAR® IAP, EarthCraft, California Title-24 and WA Ventilation Code. Lamp shall be of the LED type and be no less than (1) 11W, ENERGY STAR 2.0 certified, GU24 base LED lamp that maintains 25,000 hours rated average life.

*Can be used to comply with CALGreen when controlled by the Panasonic Condensation Sensor Plus.

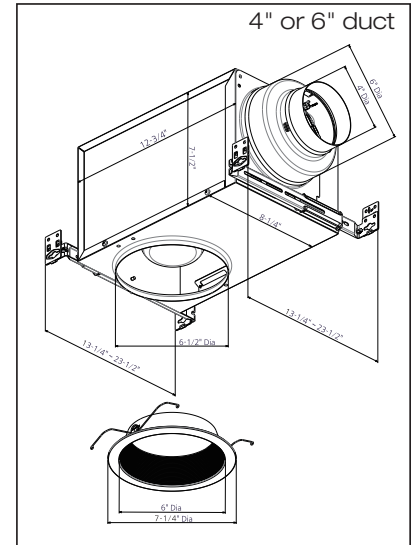

FV-08VRE2

Performance Curve 4" or 6" duct

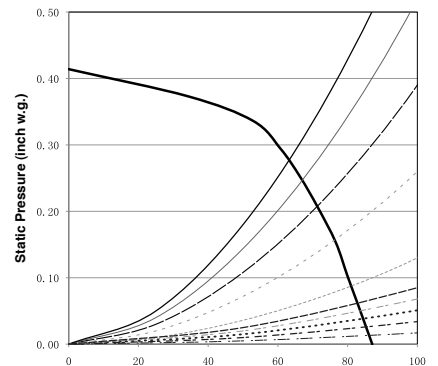

Specifications: WhisperRecessedLED FV-08VRE2	4" or 6" Duct	
Static Pressure in inches w.g.	0.1	0.25
Air Volume (CFM)	80	66
Noise (sones)	1.0	0.8
Power Consumption (watts)	18.5	17.6
Energy Efficiency (CFM/Watt)	4.4	3.8
Speed (RPM)	1342	1480
Current (amps)	0.15	0.15
MAX Current (amps)	0.19	
Power Rating (V/Hz)	120/60	
ENERGY STAR rated	YES	

0.25 = Installed Performance

Dimmer Switch Compatibility				
Brand	Series	Model	Load	Dimmability
Lutron	Eco-dim	D-603PG	600W	OK
	Maestro	MA-600	600W	OK*
	Diva	DV-600PR	600W	OK
	Skylark	S-600	600W	OK
	Toggler	G-600PR	600W	OK
Leviton	Vizia +	VP106	600W	OK
Cooper	Aspire	9540	1000W	OK

*Minimum 3 lamps

For complete Installation Instructions visit us.panasonic.com/ventfans

Model	Quantity	Comments	Project:
			Location:
			Architect:
			Engineer:
			Contractor:
			Submitted by:
			Date:

Panasonic Eco Solutions North America
Eco Products Division
Two Riverfront Plaza
Newark, NJ 07102

us.panasonic.com/ventfans



Specification Submittal Data / Panasonic Ventilation Fan

Description:

Ventilation fan/LED light shall be low sone ceiling mount rated for continuous run. Fan shall be ENERGY STAR® rated and certified by the Home Ventilating Institute (HVI). Fan shall include energy efficient LED lighting. Evaluated by Underwriters Laboratories and conform to both UL and cUL safety standards.

Motor/Blower:

- Four-pole fully enclosed condenser motor rated for continuous operation.
- Power rating shall be 120 volts and 60 Hz.
- Fan shall be UL listed for tub/shower enclosure when GFCI protected and used in insulated ceiling (TYPE I.C.).
- Motor equipped with thermal-cut-off fuse.
- Removable, permanently lubricated, plug-in motor.

Housing:

- Rust proof epoxy and polyester resin coating, 26 gauge galvanized steel body.
- Integrated dual 4" or 6" diameter duct adapter.
- Metal flange around recessed light aperture helps provide an Air Barrier and assists with the decrease in leakage in the Building Envelope during blower door testing.
- Built in backdraft damper.
- Expandable extension bracket up to 24".
- Double hanger bar system allows for ideal positioning.

Trim Ring:

- Attractive design using Poly Pro material.
- Attaches directly to housing with torsion springs.



(1) 11 Watt GU24 base LED lamp/2700 Kelvin Warm White/>90CRI/750 lumens/68 LPW/ ENERGY STAR 2.0 certified/25,000 hours rated average life.

Light:

- One 11W, ENERGY STAR 2.0 certified, GU24 base LED lamp.
- 2700 Kelvin Warm White/>90CRI/750 lumens/68 LPW/25,000 hour rated average life.
- LED lamp is dimmable.
- FCC Part 15 compliant.

Warranty:

- ALL Parts: 3 Years from original purchase date.
- LED: 5 years from original purchase date.

Architectural Specifications:

Ventilation fan and LED light combination shall be ceiling mount, ENERGY STAR® rated type, with no less than 80 CFM and no more than 1.0 sone as certified by the Home Ventilating Institute (HVI) at 0.1 w.g. with no less than 66 CFM and no more than 0.8 sone at .25 w.g. Power consumption shall be no greater than 18.5 watts at 0.1 w.g. and 17.6 Watts at 0.25 w.g. ENERGY STAR® rated with efficiency of no less than 4.4 CFM/watt at 0.1 w.g. and than 3.8 CFM/watt at 0.25 w.g. The motor shall be fully enclosed, four pole condenser type engineered to operate continuously. Power rating shall be 120v/60Hz. Duct diameter shall be no less than 4", inclusive of an integrated dual 4" or 6" duct adapter. Fan shall be UL and cUL listed for tub/shower enclosure when GFCI protected. Fan housing shall be Type IC. Fan can be used to comply with ASHRAE 62.2, LEED, CALGreen*, ENERGY STAR® IAP, EarthCraft, California Title-24 and WA Ventilation Code. Lamp shall be of the LED type and be no less than (1) 11W, ENERGY STAR 2.0 certified, GU24 base LED lamp that maintains 25,000 hours rated average life.

*Can be used to comply with CALGreen when controlled by the Panasonic Condensation Sensor Plus.

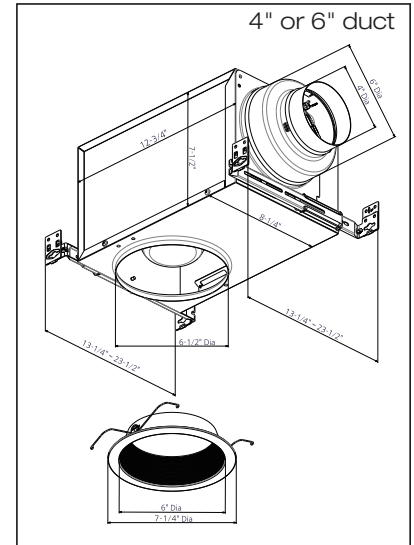

FV-08VRE2

Performance Curve 4" or 6" duct

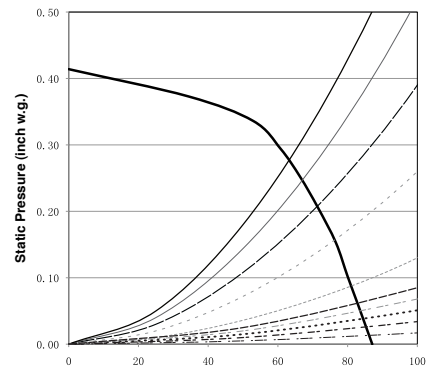

Specifications: WhisperRecessedLED FV-08VRE2	4" or 6" Duct	
Static Pressure in inches w.g.	0.1	0.25
Air Volume (CFM)	80	66
Noise (sones)	1.0	0.8
Power Consumption (watts)	18.5	17.6
Energy Efficiency (CFM/Watt)	4.4	3.8
Speed (RPM)	1342	1480
Current (amps)	0.15	0.15
MAX Current (amps)	0.19	
Power Rating (V/Hz)	120/60	
ENERGY STAR rated	YES	

0.25 = Installed Performance

Dimmer Switch Compatibility				
Brand	Series	Model	Load	Dimmability
Lutron	Eco-dim	D-603PG	600W	OK
	Maestro	MA-600	600W	OK*
	Diva	DV-600PR	600W	OK
	Skylark	S-600	600W	OK
	Toggler	G-600PR	600W	OK
Leviton	Vizia +	VP106	600W	OK
Cooper	Aspire	9540	1000W	OK

*Minimum 3 lamps

For complete Installation Instructions visit us.panasonic.com/ventfans

Model	Quantity	Comments	Project:
			Location:
			Architect:
			Engineer:
			Contractor:
			Submitted by:
			Date:

Panasonic Eco Solutions North America
Eco Products Division
Two Riverfront Plaza
Newark, NJ 07102

us.panasonic.com/ventfans

