

Extreme Temperatures High Bay and Low Bay Sensors

Features

- Digital passive infrared sensor. Low profile design, no minimum load
- Two (2) Built-in photocell for daylight harvesting
- 120-347V AC, 1 relay
- Supports mounting heights up to 45 ft for high bay configurations and between 8-16 ft for low bay configurations

Ordering Information

Description	Device Color	UPC Number	Catalog Number
High bay PIR sensor, 1 relay with photocell for Harsh Enviroments	White	783585565095	HBSXT13

Listings

cULus Listed
Meets ASHRAE 90.1
CEC Title 24 Compliant

Specifications

Casing	High-impact injection-molded thermoplastic
Size	4.0" Diameter x 1.5" height
Weight	7 oz.
Mounting	Mounts directly to the end of a fixture

Performance

Electrical	
Lighting Load Capacity	120V AC: 0-800 watts ballast, tungsten LED driver. 277V AC: 0-1200 watts ballast, 5A LED driver. 347V AC: 0-1500 watts ballast
Motor load	1/4HP @ 120V AC, 1/6 HP @ 347V
User Interface	12-pin DIP switch
Environment	
Moisture Resistance	IP65 Suitability
Operating temperature	-40°F to 149°F (-40°C to 65°C)
Relative humidity	0% to 95%
Timer time-outs	
Primary	8-second test mode 4, 8, 16 and 30 minutes.
Secondary	Disabled, 30, 60 and 90 minutes. Available on dual relay versions only.

HUBBELL

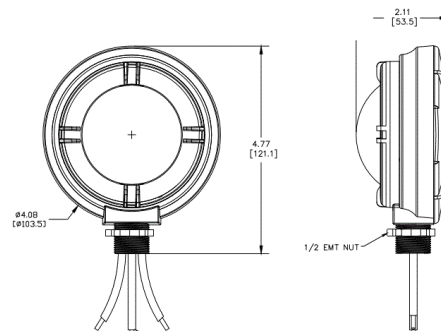
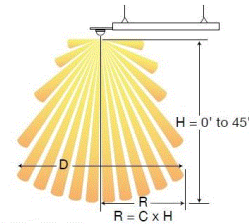

Complementary Products

IP65 High bay replacement lens, 360°	HBRLXT360
IP65 Low bay replacement lens, 360°	LBRLXT360

Online Resources

Customer Use Drawing
eCatalog
Installation Instructions

Extreme Temperatures High Bay and Low Bay Sensors

Features

- Digital passive infrared sensor. Low profile design, no minimum load
- Two (2) Built-in photocell for daylight harvesting
- 120-347V AC, 1 relay
- Supports mounting heights up to 45 ft for high bay configurations and between 8-16 ft for low bay configurations

Ordering Information

Description	Device Color	UPC Number	Catalog Number
High bay PIR sensor, 1 relay with photocell for Harsh Enviroments	White	783585565095	HBSXT13

Listings

cULus Listed
Meets ASHRAE 90.1
CEC Title 24 Compliant

Specifications

Casing	High-impact injection-molded thermoplastic
Size	4.0" Diameter x 1.5" height
Weight	7 oz.
Mounting	Mounts directly to the end of a fixture

Performance

Electrical

Lighting Load Capacity	120V AC: 0-800 watts ballast, tungsten LED driver. 277V AC: 0-1200 watts ballast, 5A LED driver. 347V AC: 0-1500 watts ballast
Motor load	1/4HP @ 120V AC, 1/6 HP @ 347V
User Interface	12-pin DIP switch

Environment

Moisture Resistance	IP65 Suitability
Operating temperature	-40°F to 149°F (-40°C to 65°C)
Relative humidity	0% to 95%

Timer time-outs

Primary	8-second test mode 4, 8, 16 and 30 minutes.
Secondary	Disabled, 30, 60 and 90 minutes. Available on dual relay versions only.

HUBBELL

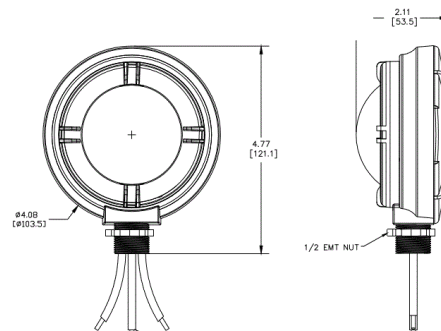
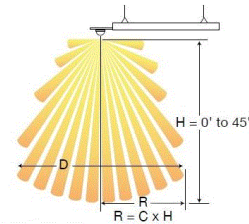

Complementary Products

IP65 High bay replacement lens, 360°	HBRLXT360
IP65 Low bay replacement lens, 360°	LBRLXT360

Online Resources

Customer Use Drawing
eCatalog
Installation Instructions