

Carflex® Liquidtight Fittings

90° Fittings

- For Use with Carflex® conduit and Carflex® X-Flex™ conduit

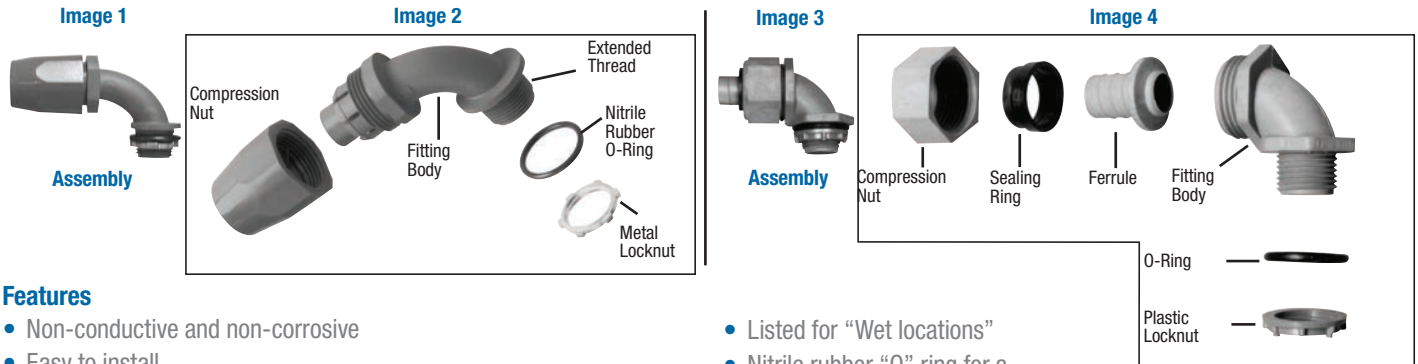

Features

- Non-conductive and non-corrosive
- Easy to install
- Resistant to oil, acid, ozone and alkaline
- Approved for indoor and outdoor locations
- Listed for “Wet locations”
- Nitrile rubber “O” ring for a liquidtight termination
- Temperatures up to 107°C

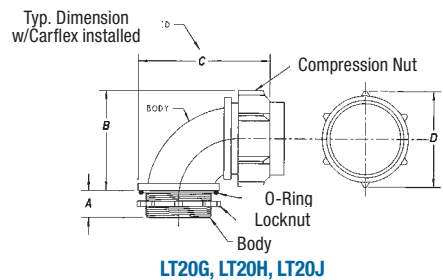
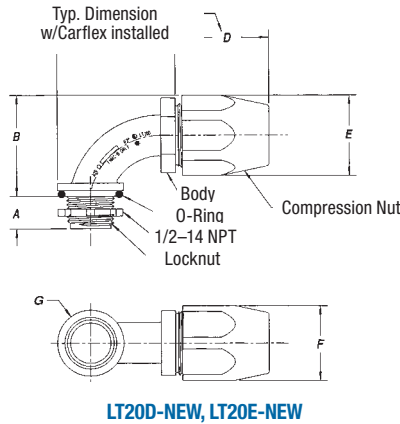
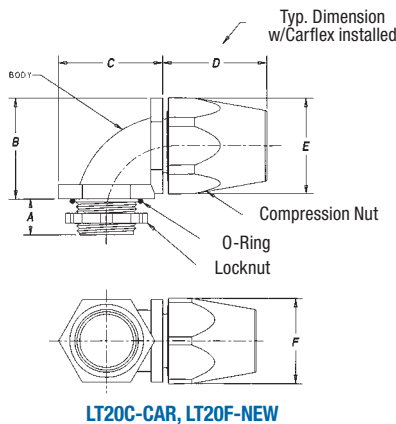

Specifications



Cat. No.	Size (in.)	Std. Ctn. Qty.	Std. Ctn. Wt. (lb.)	Dimensions (in.)							Refer to Image
				A	B	C	D	E	F	G	
LT20C	3/8	50	3.6	0.56	1.44	1.44	1.56	1.39	1.26	-	1-2
LT20D-NEW	1/2	50	4.2	0.56	1.76	2.05	1.62	1.40	1.30	1.15	1-2
LT20E-NEW	3/4	50	6.6	0.56	2.04	2.35	1.88	1.71	1.61	1.50	1-2
LT20F-NEW	1	25	5.5	0.70	2.01	2.01	2.26	2.04	1.90	-	1-2
LT20G	1-1/4	5	1.5	0.75	2.50	3.55	2.48	-	-	-	3-4
LT20H	1-1/2	5	2.0	0.75	2.80	3.98	2.77	-	-	-	3-4
LT20J	2	5	2.5	0.94	3.48	4.56	3.33	-	-	-	3-4