

# BEAM CLAMPS

FOR 1 5/8" (41 MM) WIDTH SERIES CHANNEL



1 5/8" Channels

Nuts & Hardware

General Fittings

Pipe/Conduit Supports

Electrical Fittings

Concrete Inserts

1 1/4" Framing System

1 3/16" Framing System

Spec. Metals & Fiberglass

Index

## P2785

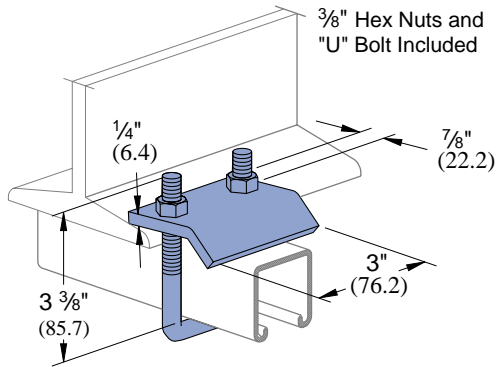

Design Load Each  
1000 Lbs (4.4 kN)  
Use in Pairs Only

- For use with Beams up to 3/4" (19.1) Flanges and with Channels P1000, P1100, P2000, P3000, P3300, P3301, P4000, P4001, P4100, and P4101.

Wt/C 83 Lbs (37.6 kg)

## P2786

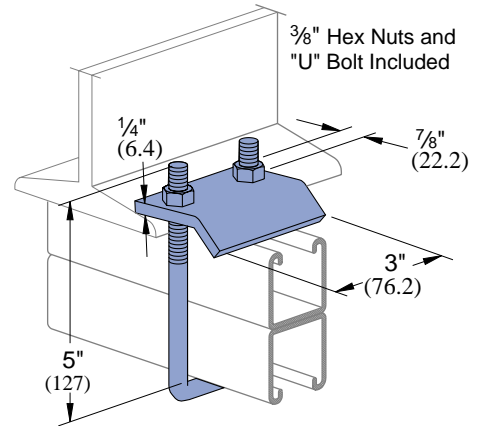

Design Load Each  
1000 Lbs (4.4 kN)  
Use in Pairs Only

- For use with Beams up to 3/4" (19.1) Flanges and with Channels P1001, P1101, P2001, P3001, P5000, and P5500.

Wt/C 92 Lbs (41.7 kg)

## P2824-6,-9,-12

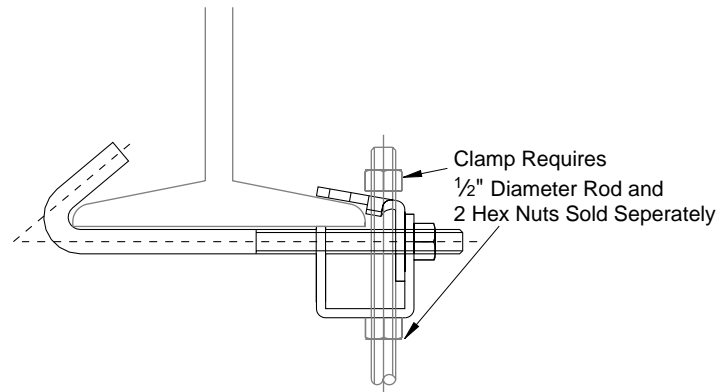
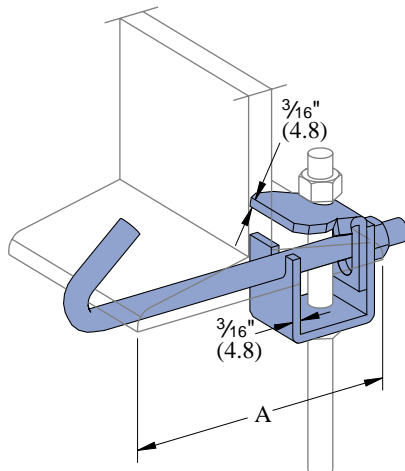

Part Number	"A"		Weight/C		Design Load	
	In	mm	Lbs	kg	Lbs	kN
<b>P2824-6</b>	2 1/2 - 6	63.5 - 152.4	125	56.7	500	2.2
<b>P2824-9</b>	5 1/2 - 9	139.7 - 228.6	140	63.5	500	2.2
<b>P2824-12</b>	8 1/2 - 12	215.9 - 304.8	171	77.6	500	2.2

**Perma-Gold™ (ZD):**

Perma-Gold™ Industry Standard Yellow Dichromate

The high quality Perma-Gold finish is a zinc dichromate finish applied over an electro-galvanized zinc plating and is totally compatible with the aesthetics and performance of yellow dichromate finishes used on other brands of metal framing.

A .5 mil electro-galvanized plating is used instead of a standard galvanized coating. This creates a cohesive molecular bond between the steel and the applied zinc coating. The strength of this bond repels corrosion and prevents future blistering and peeling. This electro-galvanization process, performed in compliance with specification ASTM B633, ensures an even distribution of the zinc.

The gold colored zinc dichromate is applied over the electro-galvanized surface to produce a chemically-bonded, nonporous surface barrier. This provides protection from moisture and air to extend the life of the zinc and to provide an excellent surface for painting if desired. The Perma-Gold finish also provides a low electrical resistance when the system needs to be grounded. To eliminate exposed surfaces, the channels and fittings are plated after all fabrication. The zinc coating provides sacrificial protection on exposed edges when field cutting is necessary or scratches occur during construction and handling.

The long-term corrosion resistance of zinc is directly proportional to thickness. Industrial grade finishes with heavier zinc finishes for greater long-term protection are also available and are described on the reverse side.

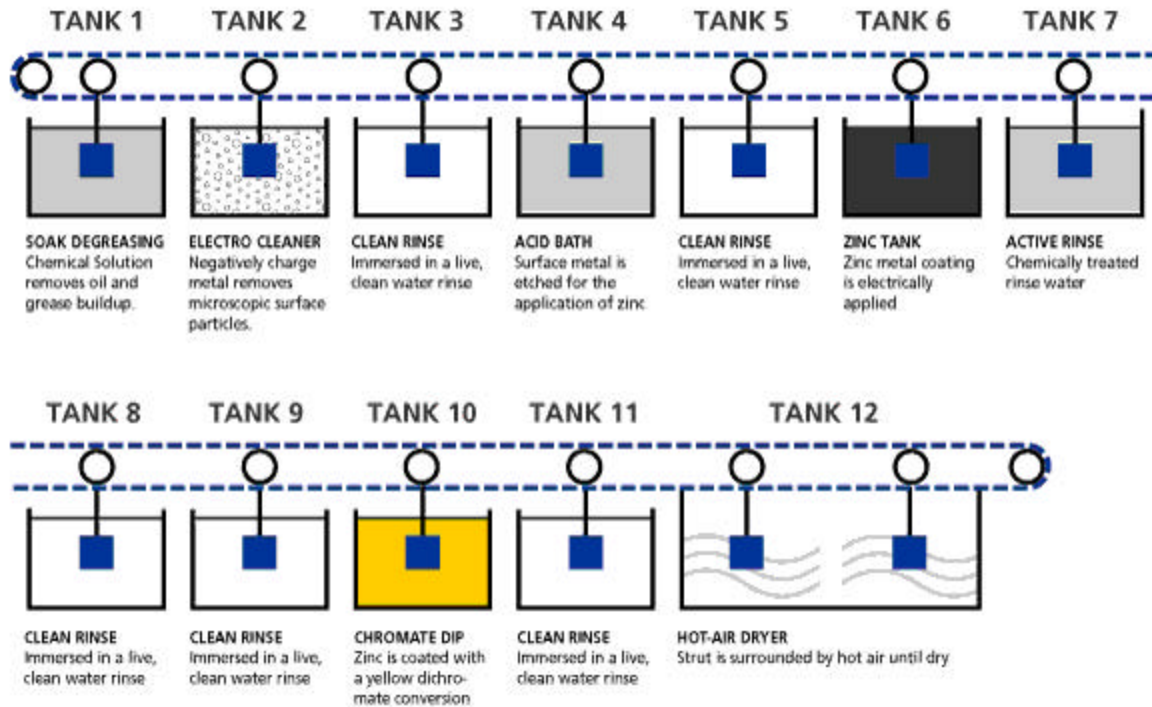

# BEAM CLAMPS

FOR 1 5/8" (41 MM) WIDTH SERIES CHANNEL



1 5/8" Channels

Nuts & Hardware

General Fittings

Pipe/Conduit Supports

Electrical Fittings

Concrete Inserts

1 1/4" Framing System

1 3/16" Framing System

Spec. Metals & Fiberglass

Index

## P2785

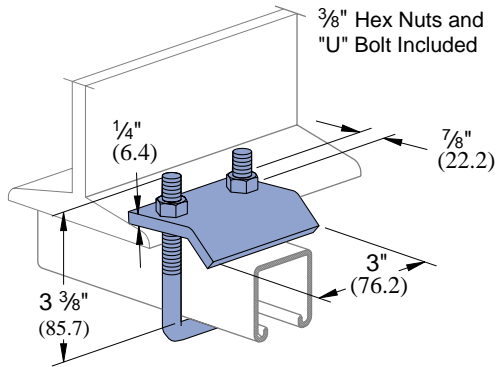

Design Load Each  
1000 Lbs (4.4 kN)  
Use in Pairs Only

- For use with Beams up to 3/4" (19.1) Flanges and with Channels P1000, P1100, P2000, P3000, P3300, P3301, P4000, P4001, P4100, and P4101.

Wt/C 83 Lbs (37.6 kg)

## P2786

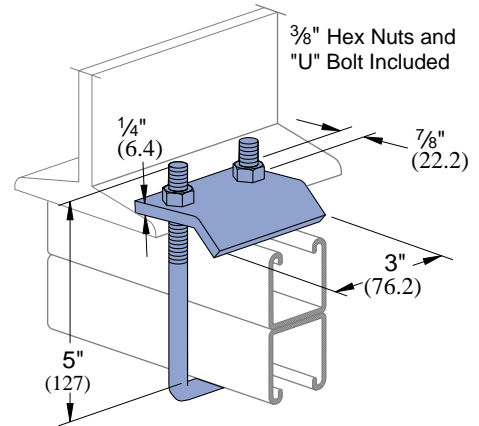

Design Load Each  
1000 Lbs (4.4 kN)  
Use in Pairs Only

- For use with Beams up to 3/4" (19.1) Flanges and with Channels P1001, P1101, P2001, P3001, P5000, and P5500.

Wt/C 92 Lbs (41.7 kg)

## P2824-6,-9,-12

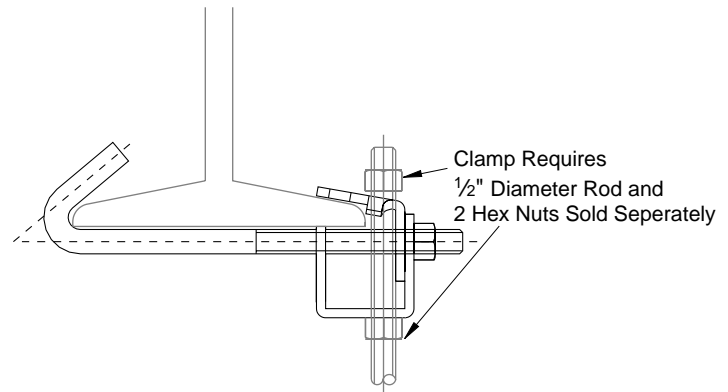
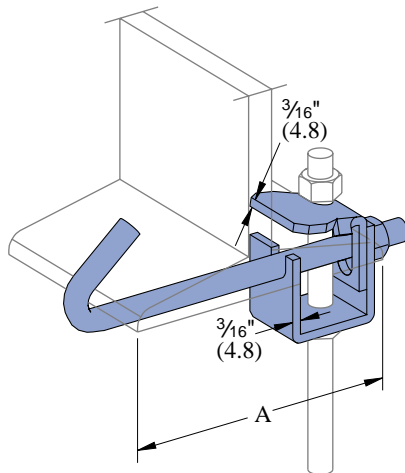

Part Number	"A"		Weight/C		Design Load	
	In	mm	Lbs	kg	Lbs	kN
<b>P2824-6</b>	2 1/2 - 6	63.5 - 152.4	125	56.7	500	2.2
<b>P2824-9</b>	5 1/2 - 9	139.7 - 228.6	140	63.5	500	2.2
<b>P2824-12</b>	8 1/2 - 12	215.9 - 304.8	171	77.6	500	2.2

**Perma-Gold™ (ZD):**

Perma-Gold™ Industry Standard Yellow Dichromate

The high quality Perma-Gold finish is a zinc dichromate finish applied over an electro-galvanized zinc plating and is totally compatible with the aesthetics and performance of yellow dichromate finishes used on other brands of metal framing.

A .5 mil electro-galvanized plating is used instead of a standard galvanized coating. This creates a cohesive molecular bond between the steel and the applied zinc coating. The strength of this bond repels corrosion and prevents future blistering and peeling. This electro-galvanization process, performed in compliance with specification ASTM B633, ensures an even distribution of the zinc.

The gold colored zinc dichromate is applied over the electro-galvanized surface to produce a chemically-bonded, nonporous surface barrier. This provides protection from moisture and air to extend the life of the zinc and to provide an excellent surface for painting if desired. The Perma-Gold finish also provides a low electrical resistance when the system needs to be grounded. To eliminate exposed surfaces, the channels and fittings are plated after all fabrication. The zinc coating provides sacrificial protection on exposed edges when field cutting is necessary or scratches occur during construction and handling.

The long-term corrosion resistance of zinc is directly proportional to thickness. Industrial grade finishes with heavier zinc finishes for greater long-term protection are also available and are described on the reverse side.

