

4

3

2

1

REVISIONS					
REV.	EC. NO.	DATE	DESCRIPTION	CREATED BY	CHECKED BY
A		6/25/2024	RELEASE	LGR	
B		7/25/2024	NOTES EDIT	LGR	

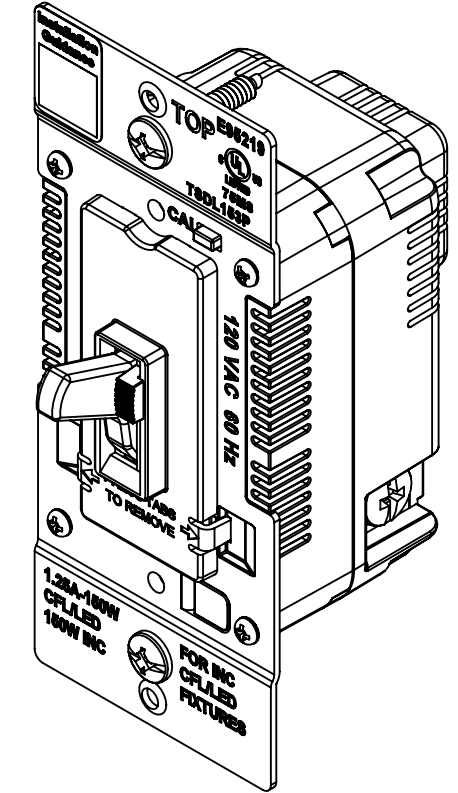
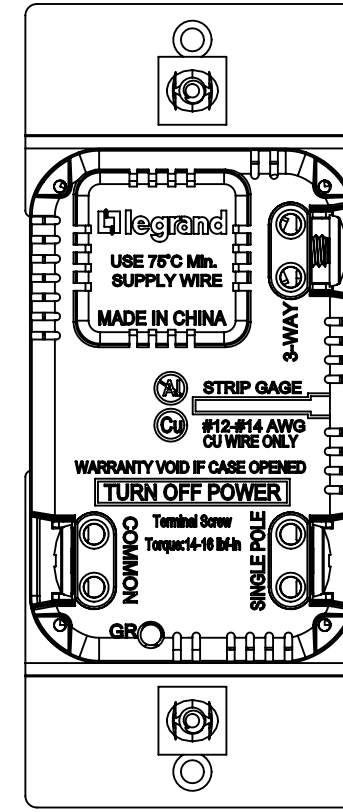
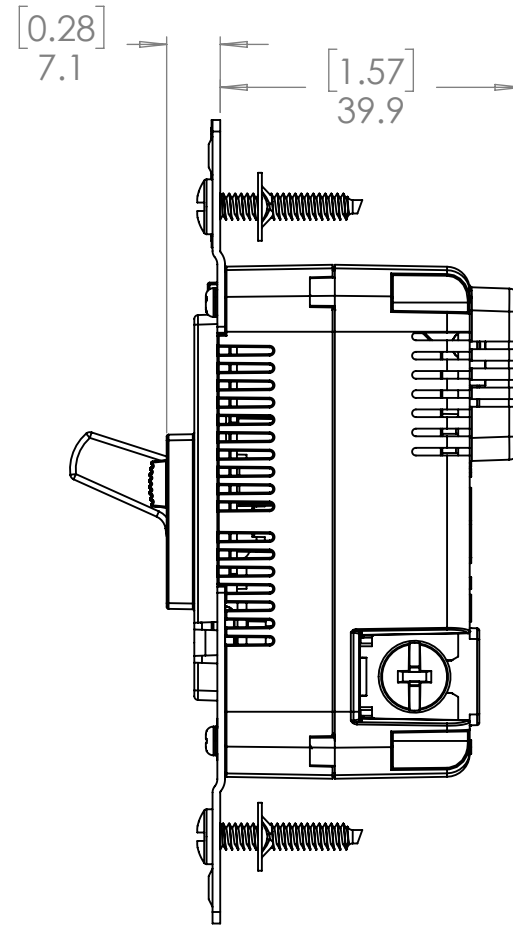
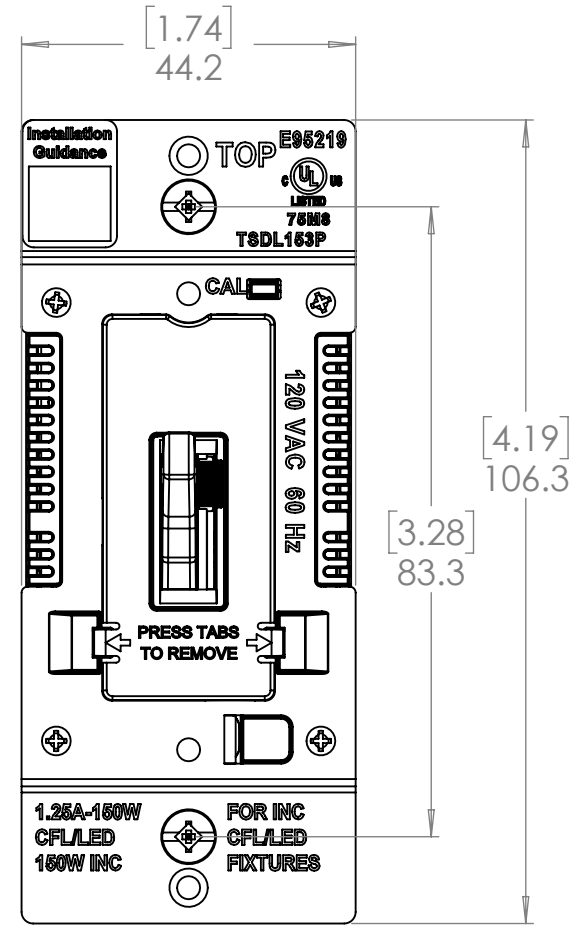
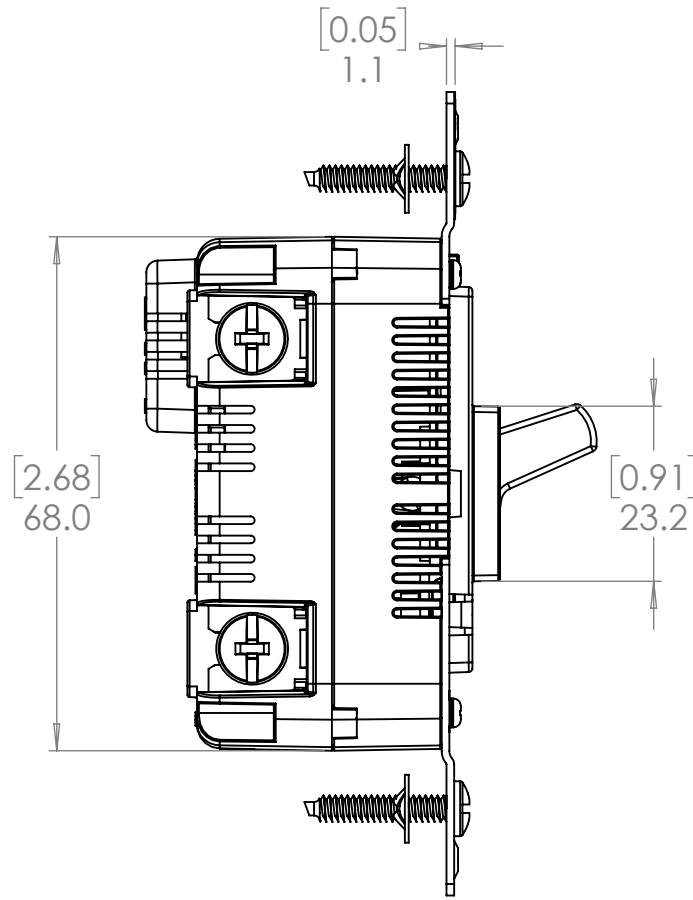

- NOTES:
- TYPE: TOGGLE SLIDE LED ADVANCED DIMMER SWITCH. SET LIGHT LEVELS AND ADJUST BRIGHTNESS TO SAVE ENERGY AND CREATE THE PERFECT LIGHTING FOR ANY ACTIVITY. DESIGNED SPECIFICALLY FOR LED LIGHTING UP TO 150W.
 - BASE CATALOG NUMBER: TSDL153P
 - ELECTRICAL RATINGS: 120VAC 60Hz
 - 120VAC, 1.25A-150W LED
 - 120VAC, 1.25A-150W CFL/INC
 - 3RD PARTY:
 - CULUS 1472
 - CULUS C22.2 NO 184.1-96
 - NEMA SSL7A COMPLIANT
 - NEMA SSL 7A WAS DEVELOPED TO HELP IMPROVE COMPATIBILITY AND PERFORMANCE OF FORWARD PHASE-CUT DIMMERS AND LED LIGHT SOURCES SO END USERS WILL HAVE A BETTER DIMMING EXPERIENCE.
 - SAFETY/ENERGY CONSUMPTION: INCLUDES A POWER LIMITING ALGORITHM TO REDUCE OUTPUT WITH POWER DRAWS OVER A 150W.
 - WORKS WITH FORWARD PHASE DIMMABLE LED LOADS, NO NEUTRAL WIRE REQUIRED
 - TERMINATION:
 - BACK WIRE SCREW TERMINALS
 - TORQUE 14-16 LBF-IN
 - WIRED GROUND LEAD (6")
 - MATERIAL: POLYCARBONATE

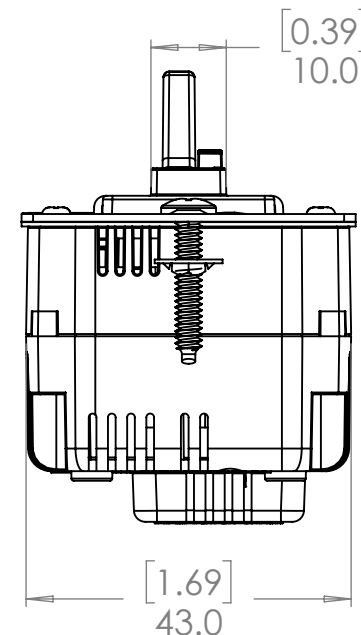

Catalog Number	Color
TSDL153PW	White
TSDL153PLA	Light Almond
TSDL153PI	Ivory
TSDL153PBK	Black
TSDL153PGRY	Gray
TSDL153P	Brown
TSDL153PRED	Red

ENVIRONMENTAL MATERIAL REQUIREMENTS
 MATERIALS, PRODUCTS, PARTS AND ASSEMBLIES PROVIDED UNDER THIS DRAWING MUST MEET THE REQUIREMENTS DETAILED IN THE LATEST REVISION OF THE LEGRAND, NORTH & CENTRAL AMERICA CORPORATE ENVIRONMENTAL MATERIAL REQUIREMENTS (EMR) DOCUMENT EMS-009. ANY DEVIATION FROM THE EMR REQUIREMENTS MUST BE APPROVED BY AN AUTHORIZED REPRESENTATIVE OF LEGRAND PRODUCT ENGINEERING IN WRITING. THE LATEST EMR DOCUMENT IS AVAILABLE ON REQUEST.

- Preset, Single Pole and 3-Way operation.
- Constant memory returns lights to previous level after a power failure.
- Compatible with forward phase dimmable LED bulbs and fixtures.
- No de-rating required in multi-gang applications.
- SSL 7A Compliant for Title 24 requirements
- No Neutral connection required.

Unspecified Tol. Frac ±1/64 Angles ±1.0	Drawing Title CUSTOMER DRAWING TSDL153P	Scale: 1:1
DO NOT SCALE DRAWING	Model Number: TSDL153P	Sheet: 1 of 1
Created By: LGR	Date: 6/25/2024	Rev. B
P&S Drawing No. CAD3346-PS-TSDL153P		

4

3

2

1