

REV.	DATE	DESCRIPTION	ECO	BY	C'H'K.
A	5/21/2007 9:00:00 AM	NEW DRAWING	14331	TRF	MAC

Y644-HSXT DIELESS HYPRESS™

- Dieless system, eliminates the need to purchase and maintain dies.
- Patented rapid advance pump for faster crimps.
- Pressure relief "pop-off" valve provides audible indication that crimp is complete.
- Handle trigger drain for convenient ram retraction.
- 355° head rotation for versatile tool positioning in tight areas.
- Easy inspection and positive identification is provided with embossment of the BURNDY® logo with every crimp.
- Comfort grip handles help ease fatigue with continuous use.
- Supplied with high impact plastic carrying case.
- Five year warranty and two years on all tools repaired by an Authorized BURNDY® Tool Repair Center.

SPECIFICATIONS

Output Force : 11 tons (22,000 lbs.)
 Weight : 15 lbs. (5.6 kg)
 Length : 23.2" (589.3 mm)
 Height : 3.00" (76.2 mm)
 Width : 7.04" (178.8 mm)

FOR USE ON

AWG/KCMIL SIZE RANGE	CONNECTOR TYPE
Copper #6-1000 kcmil	Terminals YA-L, YA-2LN, YA, YA-FXB YA-2N, YA-L-2TC, YA-L-FX YAB-4N, YA-L-TC, YA-2L, YA-4N, YEV-P-FX, YE-P, 4E-P-FX Splices YS-L, YS, YS-T
Aluminum #6-750 kcmil	Terminals YA-A, YA-A-TN Splices YS-A
Aluminum #6-750 kcmil	HYPLUG™ AYP, AYP0

ACCESSORIES

Cat. No.	Description
PT10024162	Plastic Carrying Case for Y644HSXT

Y644HSXT Dieless HYPRESS™ Range Taking Capabilities.

The following size HYDENT™ lugs and two way splices, when crimped with the Y644HSXT Dieless HYPRESS™ Tool, produce the following UL listed range taking capabilities.

ALUMINUM CONNECTORS

Standard Wire Size	Expanded Wire Range
#6 AWG	#6 AWG
#5 AWG	#5-#6 AWG
#4 AWG	#4-#6 AWG
#3 AWG	#3-#6 AWG
#2 AWG	#2-#6 AWG
#1 AWG	#1-#2 AWG
1/0 AWG	1/0-#1 AWG
2/0 AWG	2/0-#1 AWG
3/0 AWG	3/0-#1 AWG
4/0 AWG	4/0-#1 AWG
250 kcmil	250-1/0 AWG
300 kcmil	300-2/0 AWG
350 kcmil	350-3/0 AWG
400 kcmil	400-4/0 AWG
500 kcmil	500-4/0 AWG
600 kcmil	600-250 kcmil
750 kcmil	750-500 kcmil

COPPER CONNECTORS

Standard Wire Size	Expanded Wire Range
#6 AWG	#6 AWG
#5 AWG	#5-#6 AWG
#4 AWG	#4-#6 AWG
#3 AWG	#3-#6 AWG
#2 AWG	#2-#6 AWG
#1 AWG	#1-#6 AWG
1/0 AWG	1/0-#6 AWG
2/0 AWG	2/0-#4 AWG
3/0 AWG	3/0-#2 AWG
4/0 AWG	4/0-#1 AWG
250 kcmil	250-1/0
300 kcmil	300-2/0
350 kcmil	350-3/0
400 kcmil	400-4/0
500 kcmil	500-4/0
600 kcmil	600-250
750 kcmil	750-500
800 kcmil	800-500
1000 kcmil	1000-750

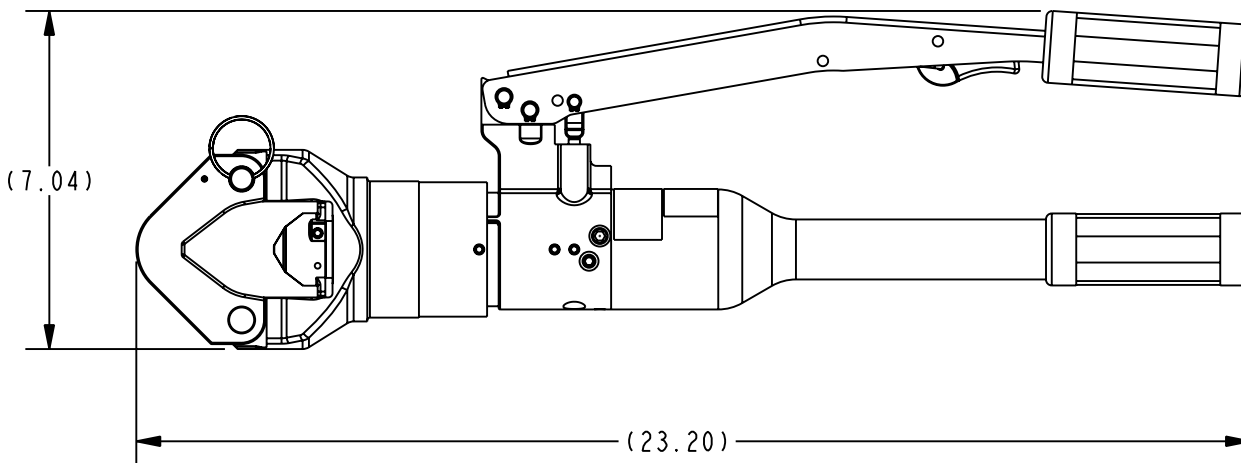
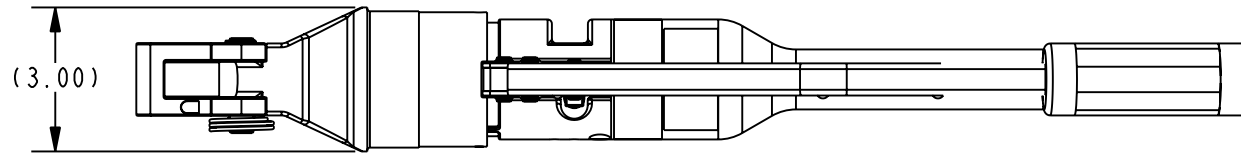

FEATURES

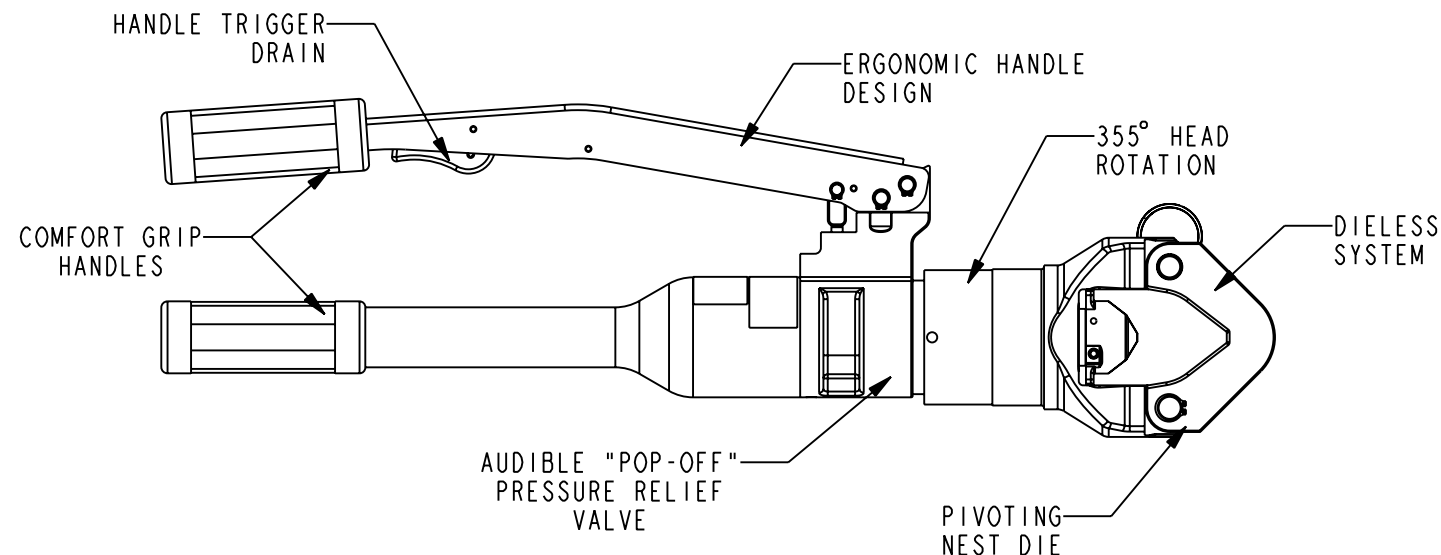

REV: PE0200

TO ORDER BURNDY PRODUCTS CALL 1-800-346-4175 MANCHESTER, NH 03109, USA FOR PRODUCT INFO = http://www.burndy.com		
Y644HSXT SELF CONTAINED TOOL		
ITEM NO: 10074290		
CAT. NO: Y644HSXT		
DRAWN BY: T. FAUCHER	04/13/2007	
CHECKER: M. CHASSON	04/13/2007	
DSN APPVL: J. LEFAVOUR	04/19/2007	
MFG APPVL: --	--	
QA APPVL: J. BRODEUR	04/19/2007	
MKT APPVL: B. POIRIER	05/17/2007	SCALE: 1:1
PROD FAM: TOOLS, HYDRAULIC	SIZE	DRAWING NO
PROJECT #: --	B	10074292
DOCUMENT TYPE: Sales		SHEET 1 OF 1
REL LEVEL: Released		A